

# HINGED CLOSURES



For Blanking Off  
Pipeline Ends,  
Tank and  
Vessel Openings

# Company Profile

## TABLE OF CONTENTS

Table of Contents	
Company Profile	2
General Information	3
General Sizes & Classes	4
Yoke Style Closures	5-18
General Information	6-9
Double-Bolt Horizontal Weights & Dims	10-11
Double-Bolt Horizontal Parts List	12
Double-Bolt Vertical Weights & Dims	13-14
Double-Bolt Vertical Parts List	15
Single-Bolt Weights & Dims	16
Single-Bolt Parts List	17
Pressure Warning Device Parts List	18
T-Bolt Closures	19-26
General Information	20-21
T-Bolt Ratings	22
T-Bolt Horizontal Weights & Dims	23-24
T-Bolt Vertical Weights & Dims	25
T-Bolt Horizontal & Vertical Parts List	26
General Terms and Conditions of Sale	27

Tube Turns was founded in 1927 in Louisville, Kentucky, as the first American manufacturer of forged seamless pipe elbows and returns. Over the years we have expanded our production capabilities to keep pace with the changing piping requirements of the industries we serve.

In the 1960's we expanded our product line to include Engineered Products which are manufactured and designed to customer requirements. Our major company focus is now directed to our Engineered Products Line. This is composed of Hinged Closures (both high and low pressure), Insulated Joints, Swel-Plug Pressure Testers, Sight Glasses, Transition Joints and other specialty piping components such as Swivel Ring Flanges, Anchor Flanges, Expander Flanges, Baffle Plates, Flued Heads, etc. Today, these products can be found throughout the Oil, Gas, Petro Chemical and Processing industries in numerous applications.

We maintain an inventory of low pressure closures and components in Carbon Steel, 304L and 316L Stainless Steel and high pressure closures and components in Carbon Steel. If materials are available in inventory, our lead time would range from stock to four weeks. We currently have a "U" stamp as required by ASME Section VIII Division 1, ensuring that our products will meet your most stringent requirements. Our experience of over 70 years in engineering, manufacturing, quality and customer service enables us to respond quickly and effectively to any customer's needs.



**Our products can be found throughout the Oil, Gas, Petro Chemical and Processing industries in numerous applications.**

# GENERAL INFORMATION

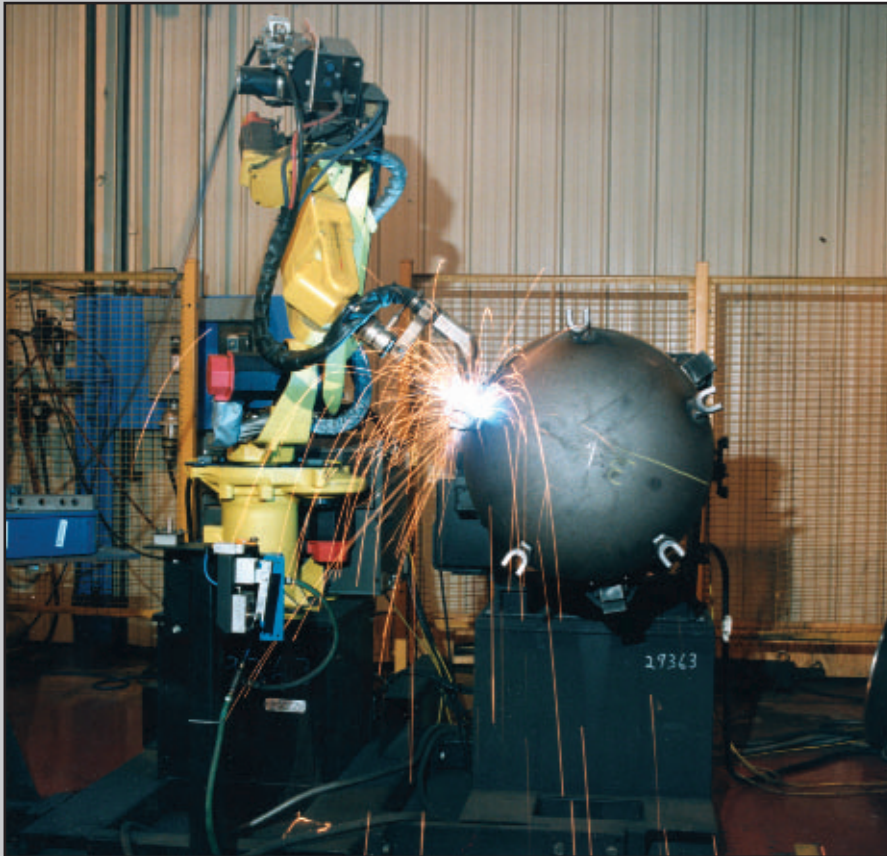

Sypris Technologies utilizes the latest in automation such as robotic welding & CNC machining

Machining of a Hub for a Yoke Style Closure. We can machine closures ranging in size from 2" through 72".



## Application

Any application where access to a closed system is required you can use a Tube Turns Hinged Closure. We offer a wide range of sizes, styles, pressure ratings, materials, and accessories.

## For Optimum Speed and Economy

More and more piping engineers and equipment designers are specifying Tube Turns Hinged Closures for blanking off or capping pipeline ends and tank or vessel openings. The reason is simple- no other closure of this type affords comparable efficiency and economy for applications where frequent access is required or where use of blind flanges is cumbersome and time consuming.

## Representative Uses

Tube Turns Hinged Closures are being employed in virtually every industrial field. Some of the more representative uses include:

### *Gas, Oil and Products Pipelines*

Scraper traps, blowdowns, scrubbers, filter separators/coalescers, terminal manifolds, meter provers, storage tanks and drier pots.

### *Processing*

Mixing and cooking vessels, extractors, filters, hand-holes in distillation towers, storage tanks, vacuum-service equipment, etc.

### *Petroleum Production and Refining*

Quick-opening blinds on "Christmas trees", sweetening vessels, storage tanks, strainers and filters.

### *Surface Transportation*

Manways on tanker trucks, hatch and manway covers on barges and ships, etc.

### *Research and Development*

Experimental reactors, pressure vessels and test chambers, laboratory and pilot-plant piping.

The singular completeness of the Tube Turns Hinged Closure line eliminates costly custom manufacture in most instances. Tube Turns offers a wide variety of standard designs, each expressly engineered for a particular area of application.



# GENERAL SIZES CLASSES

Hinged Closure Styles and Sizes			
Nomenclature	Type or Class	Nominal Sizes	Service/Rating
Double Bolt Horizontal	150H	8" - 42"	150lb (285 PSI)
	300H	8" - 42"	300lb (740 PSI)
	600H	8" - 42"	600lb (1480 PSI)
	900H	8" - 42"	900lb (2220 PSI)
	1500H	8" - 36"	1500lb (3705 PSI)
	2500H	8" - 24"	2500lb (6170 PSI)
Double Bolt Vertical *	150V	8" - 42"	150lb (285 PSI)
	300V	8" - 30"	300lb (740 PSI)
	600V	8" - 30"	600lb (1480 PSI)
	900V	8" - 24"	900lb (2220 PSI)
	1500V	10" - 20"	1500lb (3705 PSI)
	2500V	10" - 16"	2500lb (6170 PSI)
Single Bolt Closure	150S	2" - 8"	150lb (285 PSI)
	300S	2" - 8"	300lb (740 PSI)
	600S	2" - 8"	600lb (1480 PSI)
T-Bolt Hinged Closure	75 TB Horizontal	10" - 48"	see page 22
	150 TB Horizontal	6" - 48"	see page 22
	300 TB Horizontal	6" - 42"	see page 22
	75 TB Vertical	10" - 42"	see page 22
	150 TB Vertical	10" - 36"	see page 22
	300 TB Vertical	10" - 36"	see page 22

\* Larger Sizes Available with Counter Balanced Head with Weights.

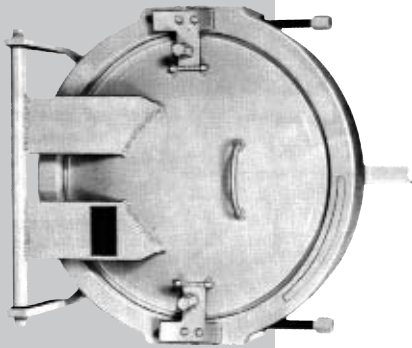

Double-Bolt Horizontal

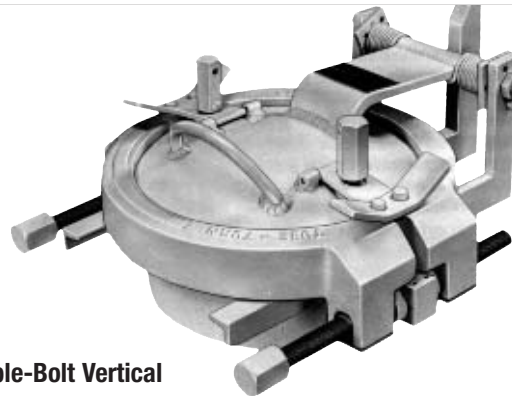

Double-Bolt Vertical

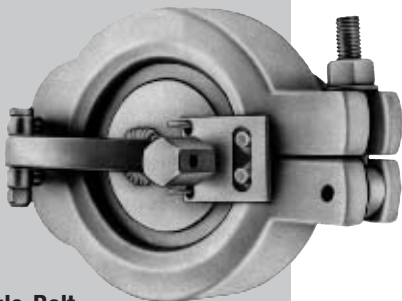

Single-Bolt



T-Bolt Hinged Closures

# YOKE STYLE CLOSURES

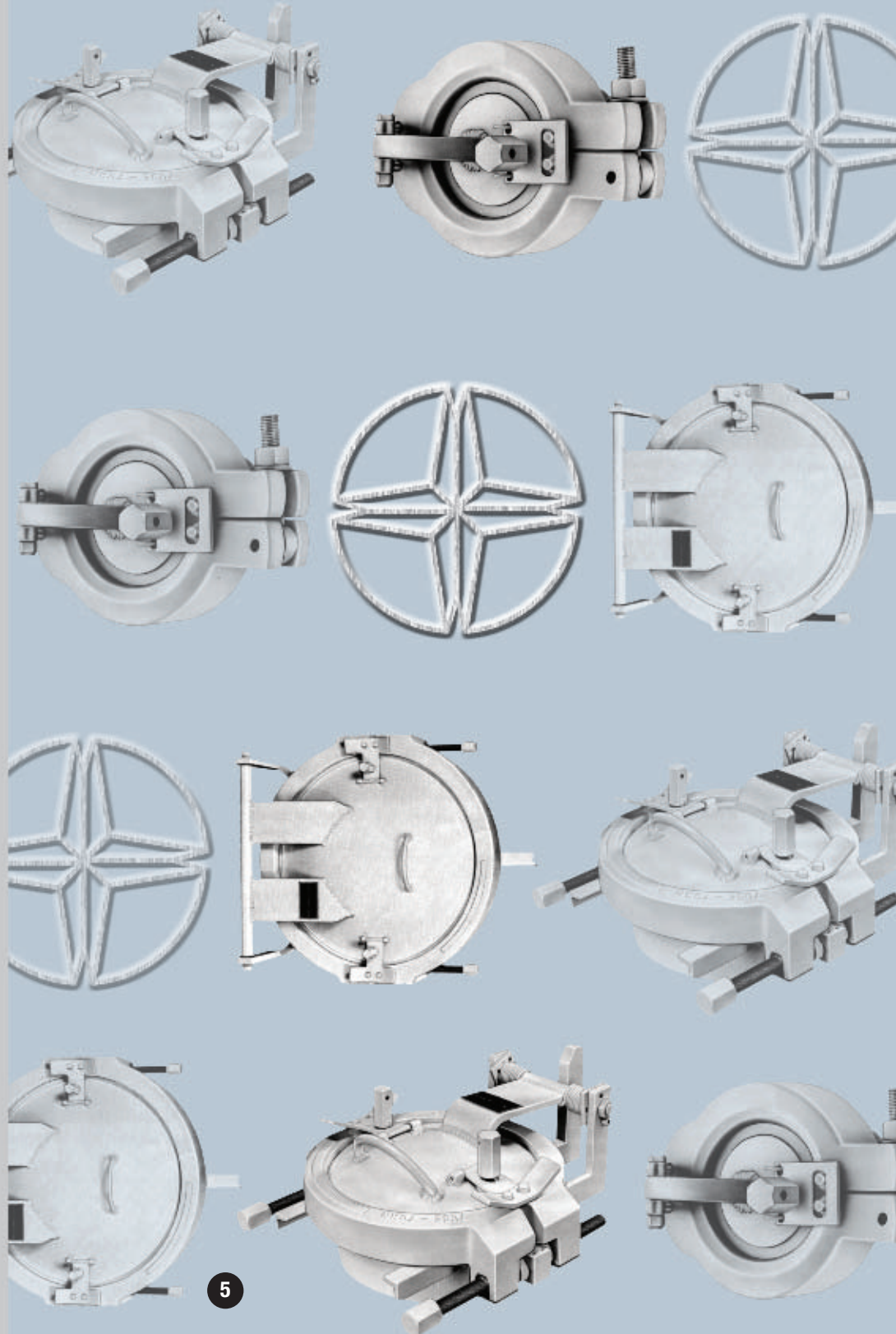

# DOUBLE BOLT YOKE CLOSURES

The Tube Turns Double Bolt Yoke Style Closure is compact in size and functional in design. A typical unit consists of a forged hub, a hinged blanking head, split-yoke clamps, operating bolts, and a self-energizing O-ring gasket. Materials of construction are in accord with ASME specifications and manufacture complies with applicable rules of the ASME Code for Pressure Piping and with the ASME Boiler and Pressure Vessel Code.

## Size and Rating

Double-bolt yoke style hinged closures are available in pressures ranging from 285 PSI to 6170 PSI and can be used in a horizontal or vertical application. They are furnished in Carbon Steel, Stainless Steel, Low Temperature materials and other alloys depending upon availability of raw material. Adding further to the completeness of Tube Turns Hinged Closures is the availability of standard designs in sizes, 2" to 42" in carbon steel, stainless steel, and other alloys. Sizes up to 72" O.D. have been produced on special orders.

## Materials of Construction

Standard construction material is Carbon Steel made to ASME specifications i.e. SA105 or SA106 grade B/C for the hub, SA516 grade 70 or SA105 for the head, SA105, SA106 Grade B/C or SA352 LCB for

the yoke, SA193 Grade B7 for yoke bolts and SA36 for structural components. Buna-N O-ring material is furnished unless another material is specified. Yoke bolts are fluorocarbon coated to lubricate the threads and prevent rust and corrosion of these working parts.

Tube Turns Hinged Closures can be equipped with sight glasses, drains, gauges, sampling ports, etc. The size and number of such openings is dependent upon the thickness of the closure head and whether threaded or socket-weld openings are utilized. Since the welding of sight glass frames, nipples, couplings and other appurtenances to the closure head or hub may result in distortion unless precautionary measures are taken; these attachments should be added at time of manufacture.

## Faster, Easier Operation

Operation is smooth and direct, and even the largest unit can be opened or closed in a matter of minutes. Turning of the actuating bolts - accomplished by one man using only standard hand tools - spreads the yoke halves until they are fully separated, allowing the head to be swung open on its hinge. There is no need to tug or hammer at bulky flanges or heavy metal doors...or to struggle with bulky lugs and threads. Contact surfaces of the clamping yokes,

head and hub are tapered and when the head is closed and the yoke bolts are tightened, the head and hub are wedged together, compressing the O-ring and effecting a leakproof seal.

## Maintenance Minimized

The standard gasket for Tube Turns Hinged Closures is an oil-resistant O-ring that is stationary when the head is being opened or closed. There is no rubbing or chafing that could cause undue wear and shorten seal life. The yokes separate evenly via the use of two yoke bolts preventing wear on the yoke contact surfaces. The yoke bolts are coated with fluorocarbon to lubricate the threads and to prevent rust and corrosion of these working parts.

Many of our closures manufactured as far back as the 1960's are still in operation only requiring periodic replacement of spare parts. Tube Turns keeps a serialized record of each closure to allow easy identification of replacement parts.

The Tube Turns Hinged Closure is remarkably easy to install, too...a single circumferential butt weld joining the closure hub to the pipe end or vessel nozzle does the job. Complete installation, operating and maintenance instructions are furnished with each Tube Turns Hinged Closure and additional copies are available upon request.



Typical of Tube Turns Yoke Type Hinged Closures being used with scraper traps.

# DOUBLE BOLT YOKE CLOSURES

## Yoke Style Closures Allowable Working Pressures (Ratings)

In general, the pressure classes established for Tube Turns Hinged Closures refer to ASME/ANSI B16.5 ratings used in normal piping terminology. This is done as a matter of convenience to give the engineer a clear understanding of service limitations and the exact Hinged Closure design required for a particular application.

Maximum allowable working pressures for carbon steel Tube Turns Yoke Type Hinged Closures are:

Closure Pressure Class	ASME/ANSI Service to 450 °F
150	285
300	740
600	1480
900	2220
1500	3705
2500	6170

## O-Ring Materials

The maximum temperatures are based on 100% compression set in 1000 hours. The O-rings may be used at higher temperatures but with an undetermined decreased life.

**“Buna-N”** - General service. Resistant to petroleum-base hydraulic and lubricating oils; animal and vegetable oils; gases such as butane, propane, acetylene and natural gas; aromatic and nonaromatic fuels such as gasoline, kerosene, diesel fuel and fuel oils; anhydrous ammonia, and water. Temperature limits: -30F to 250F; special compounds suitable for -65F.

**“Viton”** - Generally used for high-temperature services. Resistant to synthetic lubricants, petroleum-base products, some chlorinated solvents, benzene, toluene, and many acids and alkalis. Temperature limits: -20F to 400F.

### “Ethylene Propylene”

Superior resistance to phosphate-ester type fluids, Skydrol, Pydrol, Cellulubes and glycol type coolants. Excellent resistance to mild acids and alkalis. Can be used in steam service. Replacing butyl rubber in most applications. Temperature limits: -70F to 300F.

**“Silicone Rubber”** - Good resistance to high and low temperature dry gases, air, oxygen and ozone. May be satisfactory in high-aniline oils, but not recommended for use with most petroleum base products. Temperature limits: -65F to 450F.

**Note: Determination of compatibility of O-ring material with medium is the responsibility of the purchaser.**

## ASME Code-Stamped Closures

Code stamping of Tube Turns Hinged Closures is available on request at a nominal extra cost. This includes (1) the furnishing of a Partial Data Sheet verifying shop inspection of the unit by a commissioned inspector of the National Board of Boiler and Pressure Vessel Inspectors, and (2) the affixing of the ASME stamp.

## Manufacturer’s Statement of Code Compliance

In the event that shop inspection and stamping in accordance with Section VIII of the ASME Boiler and Pressure Vessel Code is not required, Tube Turns can furnish a Manufacturer’s Statement of Code Compliance. This document affirms that the Hinged Closure is manufactured in accordance with the applicable requirements of the Code.

## Ordering Data

When inquiring and/or purchasing Tube Turns Hinged Closures, please specify the following:

1. Quantity required
2. Size required
3. Material required
4. Design conditions - both pressure and temperature
5. Minimum design metal temperature - the lowest temperature to which closure will be subjected.
6. Application - horizontal (opens like a car door) or vertical (opens like a car hood)
7. Bore (wall thickness) required
8. ASME code stamp and partial data reports required
9. O-ring materials required
10. Corrosion allowance if applicable.



# DOUBLE BOLT YOKE CLOSURES

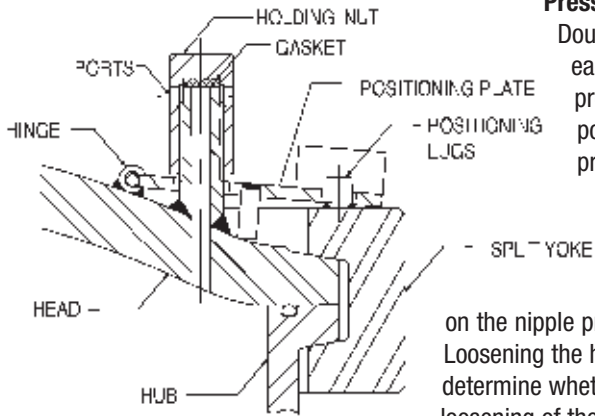

## Pressure Warning Device With Yoke Positioning Plate

Double Bolt Yoke Closures are equipped with 2 pressure warning devices on each closure. The Pressure Warning Device with yoke positioning plate provides visual and mechanical assurance that the yokes are in the correct position over the head for commencement of operations. Additionally, the pressure warning device serves the purpose of alerting the operator to any residual pressure in the vessel should the operator inadvertently attempt to open the closure before all pressure has been relieved. A pressure warning device is located at each of the yoke splits with one of the positioning lugs attached to each yoke half. Tightening the holding nut on the nipple provides a seal and locks the hinged positioning plate on the positioning lugs. Loosening the holding nut breaks the seal and provides a means by which the operator can determine whether the vessel has been completely relieved of internal pressure. Continued loosening of the holding nut will allow the disengagement of the positioning plate from the positioning lugs, permitting the yoke halves to be spread and the closure to be opened.

## Safety Locking Device

An additional feature that can be added to the Yoke Style Closure is the Safety Locking Device. This device is intended to prevent opening of the closure under pressure. It consists of a cylinder/piston connected to the interior of the closure and a latch plate. Whenever there is pressure inside the closure the piston is extended and engages the latch plate. This prevents opening of the closure under pressure. When the pressure has been reduced, the piston retracts, allowing the closure to be opened. This is a closed system and does not release its contents to the atmosphere.

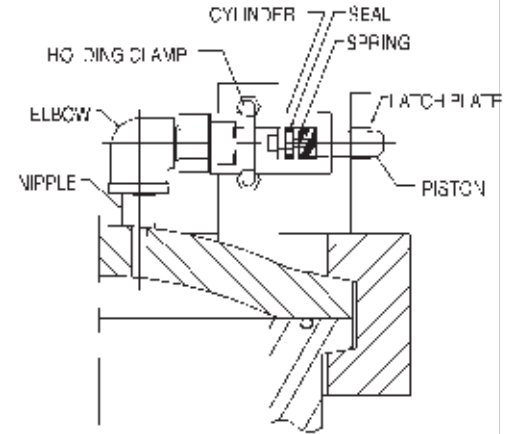

## Operating Aids

Tube Turns furnishes a variety of operating aids to speed and simplify the opening and closing of Yoke Type Closures. These range from simple, break-over wrenches, to chain-and-sprocket drives, to fully automated models. Attached break-over wrenches are available. These are attached directly to the bolts and eliminate the need for a wrench. Examples are on Page 21. The Chain and Sprocket Drive option is by far the most economical opening assist device we offer. This is a manually operated aid which assists in the opening and closing of the yoke bolts. These units not only make the process faster, they also prevent the uneven movement of the yokes which may cause binding. On larger closures, ratio reduction is available to further ease the force required to turn the unit. Hand wheels can also be furnished which provides faster operation and eliminates the need for additional tools. The basic pattern of the Tube Turns' Chain and Sprocket Drives follows the basic principal of the familiar bicycle chain and sprocket arrangement. Same size sprockets are attached to longer than standard yoke bolts. Positioned around the sprockets is a linked belt or chain. For safety precautions, a chain and sprocket guard is furnished. A lever or crank is fitted to one of the sprockets which, when turned, rotates both yoke bolts simultaneously. This device can be modified by changing the ratio of the sprockets to increase the speed and ease of opening the yoke bolts. Tube Turns can further automate their yoke style closures by designing opening and closing devices which are either electrically, pneumatically or hydraulically operated. These devices cannot only be designed to open and close the yoke bolts, but they can also raise and lower the head for vertical applications.

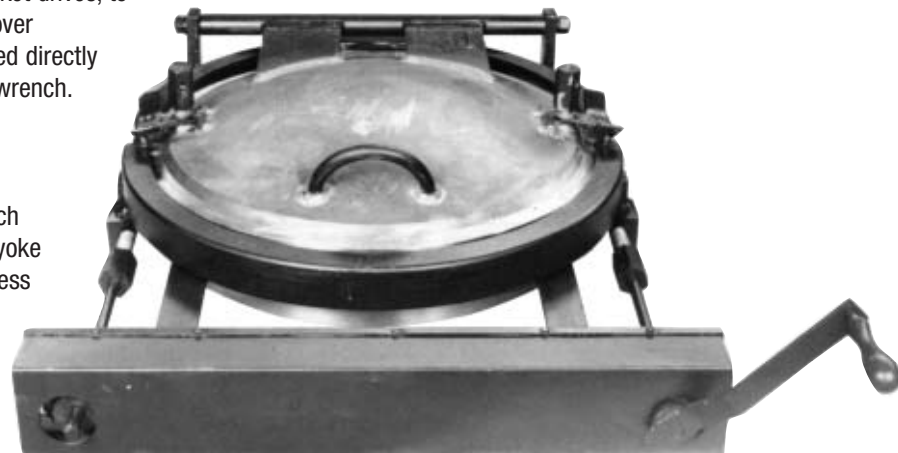

**Double Bolt Yoke Closure with Chain & Sprocket Drive.**

# DOUBLE BOLT YOKE CLOSURES

Tube Turns Automated Closures have flexibility of design and can be developed and manufactured to meet your needs. Our Automated Closures are located in industries throughout the world. Applications for Tube Turns Automated Closures include Pipeline Launchers and Receivers and operations with batch processes such as pulp and paper mills, food process, chemical plants and petrochemical plants.

In addition to this flexibility, our Automated Yoke Style Closures have other advantages.

**1. SAFETY**- Automation provides a tight seal which prevents leakage and exposure of the operators to fumes and the medium which is potentially hazardous to their health. To prevent inadvertent opening of these closures, they are normally furnished with the following safety systems:

- a. Electrically Operated Closures are equipped with a pressure switch and an electrical relay.
- b. Pneumatically Operated Closures are equipped with a pressure switch and a solenoid valve.
- c. Hydraulically Operated Closures are equipped with a pressure switch and an electrical relay.

**2. IMPROVED EMPLOYEE MORALE** - With the environmental concerns in industry today, Tube Turns' Automated Closure enables the operators to be stationed away from the reactor thus eliminating their exposure to the fumes and medium involved in the opening and closing operation. As a result, the operator's health concerns are reduced significantly. The very fact that in most instances the closure head is hinged means elimination of pinched fingers and toes or badly skinned knuckles that too often occur with the use of flanges.

### 3. ECONOMIC CONSIDERATIONS

- A. It is fast! Depending upon size, the opening and closing cycle can take less than one minute.
- B. One man can open it. He does so by merely pushing a button. As a result of these savings in operating cost, an early payback in your initial investment can be realized.

**4. MAINTENANCE** - Since operation is simple, direct and positive, Tube Turns' Automated Closures require little or no maintenance other than replacement of the O-ring and periodic inspection of yoke bolts and nuts for wear. The human element is virtually eliminated in that the automation mechanism of the closure performs all the work.

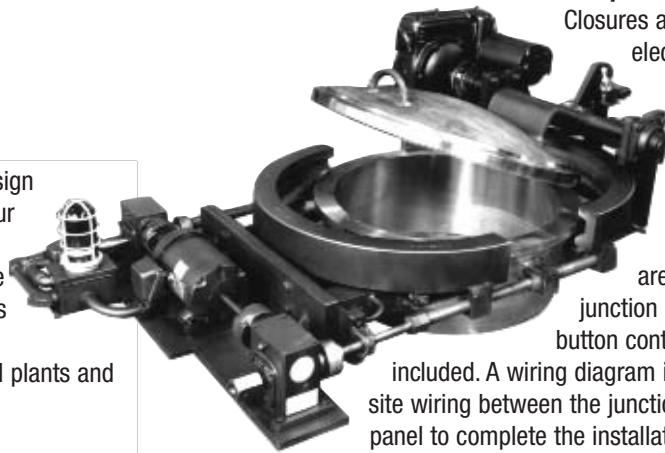

### Electric Operated Automated

Closures are supplied with electric motors and appropriate gear boxes to drive the yoke bolts and to open and close the head. Electric circuits are wired to a central junction box and a push button control panel is included. A wiring diagram is provided for on-site wiring between the junction box and control panel to complete the installation.

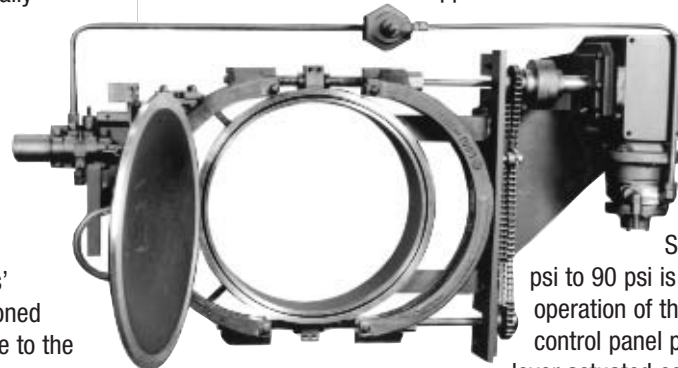

### Pneumatic Operated Automated

Closures are supplied with air driven motors, a gear box to drive the yoke bolts through a joint chain drive and a gear box to open and close the head. Shop air from 60 psi to 90 psi is used for operation of the unit through a control panel provided with lever actuated control valves.

**Hydraulic Operated Automated** Closures are similar to those described above except that hydraulic motors are used for the driving force. A hydraulic pump system with electric controls can be provided with the units or by the end user.

# DOUBLE BOLT HORIZONTAL DIMENSIONS

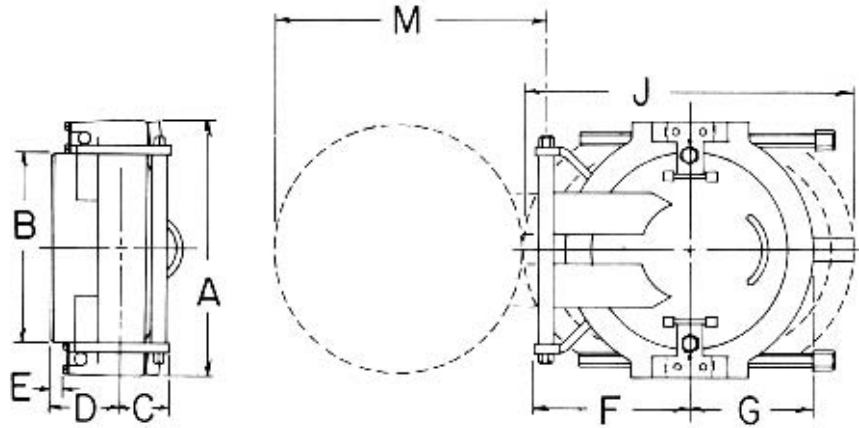

U.S. PAT. NO. 3,077,360

	Nominal Size	Over-all A	OD at Welding Bevel B	Back to Face Max. C	Hub Length D	Clear Hub Length E	Center to Hinge End F	Center to Free End G	Yoke Clearance J	Opening Clearance M	Approx. Weight Lbs
<b>Class 150-H Double Bolt Horizontal</b>	8	12 11/16	8 5/8	2 9/16	4	5/8	7 1/8	5 1/2	15 1/8	11 3/16	60
	10	14 7/8	10 3/4	2 11/16	4 1/4	7/8	8 1/2	6 3/4	18 1/8	13 1/8	80
	12	16 7/8	12 3/4	2 5/8	4 1/4	13/16	8 9/16	7 3/4	20 3/8	14 3/4	110
	14	18 1/8	14	2 11/16	4 1/4	3/4	9 5/16	8 7/16	22	16 1/8	130
	16	20 7/8	16	2 11/16	4 5/8	11/16	10 3/8	9 1/2	26 7/16	18 1/4	160
	18	22 7/8	18	2 11/16	4 5/8	11/16	11 1/2	10 1/2	28 7/16	20 1/4	190
	20	24 7/8	20	3 1/8	4 5/8	5/8	12 13/16	11 1/2	30 1/2	22 9/16	220
	22	26 7/8	22	3 1/4	4 5/8	5/8	14	12 9/16	32 1/8	24 11/16	260
	24	28 7/8	24	3 1/4	4 5/8	5/8	15	13 5/8	34 5/8	26 11/16	310
	26	30 7/8	26	3 5/16	5	1/2	16 1/16	14 11/16	37 3/8	28 13/16	370
	28	32 7/8	28	3 1/2	5	7/16	17 9/16	15 3/4	39 7/8	31 5/16	440
	30	34 7/8	30	3 5/8	5 1/2	13/16	19	16 15/16	43	33 3/8	530
	32	37 5/8	32	4	5 1/2	1/2	20 3/8	18	45 3/8	35 3/4	600
	34	39 5/8	34	4	5 1/2	1/2	21 3/8	19	47 5/8	37 3/4	680
	36	41 5/8	36	4 1/8	6	13/16	22 3/8	20 1/16	50	39 3/4	780
	38	44 1/8	38	4 1/8	6	3/4	23 3/8	21 1/8	52 3/8	41 3/4	880
	40	46 1/8	40	4 1/4	6	5/8	24 7/16	22 5/16	55 5/8	43 7/8	990
	42	48 1/8	42	4 5/8	6 1/8	5/8	25 7/16	23 5/16	57 7/8	45 7/8	1150
<b>Class 300-H Double Bolt Horizontal</b>	8	12 11/16	8 5/8	2 9/16	4	5/8	7 1/8	5 1/2	15 1/8	11 3/16	60
	10	14 13/16	10 3/4	2 11/16	4 1/4	7/8	8 1/2	6 3/4	18 1/8	13 1/8	80
	12	16 13/16	12 3/4	2 3/4	4 1/4	15/16	8 1/2	7 3/4	21	14 11/16	110
	14	18 3/16	14	2 7/8	4 1/4	15/16	9 5/16	8 7/16	22 13/16	16 1/8	140
	16	20 15/16	16	3 5/16	5	1	12 3/8	9 1/2	26 1/2	19 15/16	170
	18	23 1/8	18	3 11/16	5 1/4	7/8	12 5/8	11 3/16	29 13/16	21 3/4	220
	20	25 1/4	20	4 1/8	5 5/8	11/16	13 7/8	12 5/16	33 1/8	24	300
	22	27 3/4	22	4 1/4	6 1/4	15/16	16 3/16	13 1/8	36 3/16	27 1/16	360
	24	30 9/16	24	4 5/8	6 1/2	1 1/8	16	14 11/16	38 7/16	28 1/8	460
	26	32 1/2	26	4 13/16	6 3/4	1 1/4	19 1/2	15 7/16	42	32 1/8	570
	28	34 3/4	28	5	7 1/2	1 5/16	20 1/2	16 1/2	44 9/16	34 1/8	700
	30	36 7/8	30	5 1/8	7 3/4	1 7/16	21 11/16	17 11/16	47 11/16	36 7/16	840
	32	38 7/8	32	5 3/16	7 3/4	1 3/8	22 11/16	18 3/4	50 3/16	38 7/16	980
	34	42 1/4	34	5 7/16	8 1/4	1 3/8	21 7/8	20	53 7/16	38 3/4	1150
	36	44 1/4	36	5 7/16	8 1/2	1 9/16	23 3/8	21 1/16	56	40 3/4	1350
	38	46 3/8	38	5 5/8	8 3/4	1 11/16	24 5/8	22 1/4	59 1/16	43 1/8	1600
	40	48 7/8	40	5 13/16	9 1/4	1 11/16	25 5/8	23 3/8	62 1/16	45 3/16	1850
	42	51	42	5 15/16	9 1/2	1 7/8	26 3/4	24 1/2	64 7/16	47 3/8	2100

See notes on page 11.

# DOUBLE BOLT HORIZONTAL DIMENSIONS

	Nominal Size	Over-all A	OD at Welding Bevel B	Back to Face Max. C	Hub Length D	Clear Hub Length E	Center to Hinge End F	Center to Free End G	Yoke Clearance J	Opening Clearance M	Approx. Weight Lbs
<b>Class 600-H Double Bolt Horizontal</b>	8	12 3/4	8 5/8	2 7/8	4 1/4	5/8	8 1/8	5 15/16	16 3/4	12 5/16	90
	10	14 7/8	10 3/4	3 1/8	4 7/16	5/8	9	7 3/16	20	14 5/16	150
	12	17 5/8	12 3/4	3 5/16	5 3/16	3/8	9 3/8	8 1/4	22 3/8	15 5/8	180
	14	19	14	3 15/16	5 1/4	5/16	9 15/16	9	24 7/8	16 7/8	220
	16	21 7/8	16	4 1/4	6 1/16	9/16	13 3/16	10 11/16	29 1/8	21 3/16	380
	18	24 7/8	18	4 9/16	6 1/4	1/2	14 1/4	12 1/4	33 3/4	23 11/16	480
	20	27 1/8	20	4 13/16	7	3/8	15 5/16	13 1/2	37	25 5/16	620
	22	29 1/8	22	5 1/2	8	1 3/16	16 3/16	14 1/2	39 3/4	27 3/16	750
	24	32 1/8	24	5 3/8	8 3/8	1 3/16	17 7/8	15 3/8	42 1/2	29 13/16	900
	26	34 3/8	26	5 11/16	8 9/16	1 1/4	18 1/2	16 11/16	46 1/4	31 5/8	1120
	28	36 1/16	28	5 13/16	8 3/4	1 5/16	19 3/4	17 7/8	49 1/2	33 13/16	1380
	30	38 9/16	30	6 3/16	9 1/2	1 3/8	20 11/16	19	52 1/4	35 3/4	1700
	32	40 13/16	32	6 1/4	9 1/2	1 3/8	21 7/8	20 1/4	55 1/8	38 1/16	2000
	34	43 13/16	34	6 1/4	10	1 3/16	22 15/16	21 1/2	58 1/8	40 1/4	2320
	36	45 13/16	36	6 11/16	10 1/4	1 3/16	24 11/16	22 1/2	60 5/8	42 3/8	2750
	38	48 7/16	38	6 11/16	10 3/4	1 5/16	25 7/8	23 5/8	63 1/4	44 9/16	3280
	40	50 7/16	40	6 13/16	10 3/4	1 5/16	26 3/4	24 3/4	65 3/4	46 7/16	3450
	42	53 1/16	42	7 3/16	11 7/8	1 7/16	27 13/16	26	69 1/2	48 5/8	4000
<b>Class 900-H Double Bolt Horizontal</b>	8	12 13/16	8 5/8	3 7/16	4 9/16	9/16	9	6 1/4	18 7/16	13 5/16	140
	10	15 15/16	10 3/4	3 11/16	5 7/8	1 1/16	11 1/16	7 3/4	22 1/4	16 3/8	230
	12	18 15/16	12 3/4	4 9/16	6 3/8	11/16	12 1/2	9 3/16	25 7/8	19	340
	14	20 1/2	14	4 11/16	6 5/8	13/16	13 1/8	9 15/16	28 1/16	20 1/4	430
	16	23	16	5 1/8	7 1/2	11/16	15 7/16	11 1/4	31 1/4	23 3/16	600
	18	25 1/16	18	5 3/8	7 13/16	1	17	12 1/4	35	25 13/16	900
	20	28 3/8	20	5 15/16	8 1/2	1 1/8	17 7/8	13 1/2	37 5/8	27 3/4	1200
	22	30 1/2	22	6 1/4	8 3/4	1 3/16	19 1/8	14 13/16	40 7/8	30 1/8	1580
	24	33 1/8	24	6 5/8	9 1/2	1 1/4	20 7/16	16 1/8	44 1/2	32 9/16	2000
	26	35 1/8	26	7	9 3/4	1 9/16	21 3/4	17 1/2	47 3/4	35	2100
	28	38 1/4	28	7 3/16	10 1/2	1 3/16	24	18 3/4	51	37 13/16	2550
	30	40 3/8	30	8 5/16	10 13/16	1 1/8	25 3/16	20 1/16	54	40 1/8	3100
	32	43	32	8 5/8	11 1/2	1 7/16	26 3/4	21 5/16	57 1/2	42 3/4	3700
	34	45 3/4	34	8 1/16	12 1/2	1 5/8	27 3/4	22 5/8	61	44 7/8	4200
	36	48 5/8	36	10	13 5/16	1 13/16	30	23 15/16	64 1/2	47 3/4	5200
	38	50 5/8	38	9 11/16	13 3/8	1 11/16	31 5/16	25 3/16	67 5/8	50 1/8	5700
	40	53 3/4	40	9 3/4	13 3/4	1 9/16	32 5/8	26 1/2	70 3/4	52 9/16	6600
	42	55 7/8	42	10 9/16	14 1/8	1 3/4	34	27 13/16	74 1/8	55 1/16	7600
<b>Class 1500-H Double Bolt Horizontal</b>	6	11 13/16	6 5/8	4 3/16	6	7/8	9 1/16	5 1/2	16 3/4	12 1/2	125
	8	14 1/16	8 5/8	4 5/16	6 1/4	7/8	10 5/8	6 3/4	20 1/4	15 1/4	230
	10	17 1/16	10 3/4	4 7/8	7 1/2	1 3/8	11 7/8	8 3/8	24 1/2	17 1/2	400
	12	20 1/8	12 3/4	5 3/16	8 1/2	2 1/16	13 3/4	10	29 1/16	20 11/16	650
	14	21 5/8	14	6	8 3/4	1 9/16	15 5/16	10 3/4	30 3/4	22 5/16	800
	16	24 7/8	16	5 1/16	10	2 5/16	17	12 3/8	35	25 3/8	1200
	18	27 9/16	18	7 1/16	10 1/2	2 1/8	19	13 3/4	40	28 3/8	1600
	20	30 3/4	20	7 1/2	10 3/4	1 9/16	19 5/8	15 5/16	43 1/2	30 3/8	2200
	22	33	22	8 1/16	12	2	20	16 1/2	46	33 1/8	2700
	24	36 7/8	24	8 7/16	12 3/4	2 1/4	23 7/8	18 3/8	51	37 1/8	3550
	26	39 11/16	26	9	13 3/4	2 9/16	24 1/2	19 13/16	54 7/8	38 13/16	4500
	28	41 5/16	28	10 1/8	14 3/4	3	27	20 11/16	58 7/8	41 1/4	5200
	30	44 5/8	30	10 1/4	15 3/4	3 3/8	28 1/2	22 5/16	62 1/2	44 3/16	6200

All dimensions are in inches. When ordering, please specify type, nominal size, bore, material and service conditions. NOTE: Type H Double Bolt Horizontal model closure is normally installed with hinge at the left when viewed facing the closure. If hinge location is desired in other than left position, this information should be made available at time of order. Otherwise opening, closing and maintaining correct yoke gap are problems that can result. Tube Turns Hinged Closures are regularly furnished in carbon steel; however, closures are also available in high yield strength steels. Closures are also available in other metals and alloys and in other sizes and pressure classes on special order. Chain-and-Sprocket Drives are available at extra cost (see page 8). Attached Break-Over Wrenches are available at extra cost (see page 21). For Pressure-Temperature Ratings, see page 7.

# DOUBLE-BOLT HORIZONTAL PARTS

## Class H Double-Bolt Horizontal Parts List

1. Hub	9. Nut (RH)	17. Hub Hinge Arm (Lower)	25. Support Arm
2. Head	10. Nut (LH)	18. Hinge Tube	26. O-Ring
3. Yoke	11. Yoke Bolt	19. Hinge Bearing	27. Pressure Warning Device and Positioning Plate
4. Bolt Holder (W)	12. Wrench Lug	20. Hinge Rod	28. Positioning Lugs
5. Bolt Holder (L)	13. Wrench Lug Pin	21. Hinge Rod Nut	
6. Cap Screws	14. Cover Plate	22. Lockwasher	
7. Yoke Bolt Bushing	15. Cap Screws	23. Head Hinge Arm	
8. Collar	16. Hub Hinge Arm (Upper)	24. Head Handle	

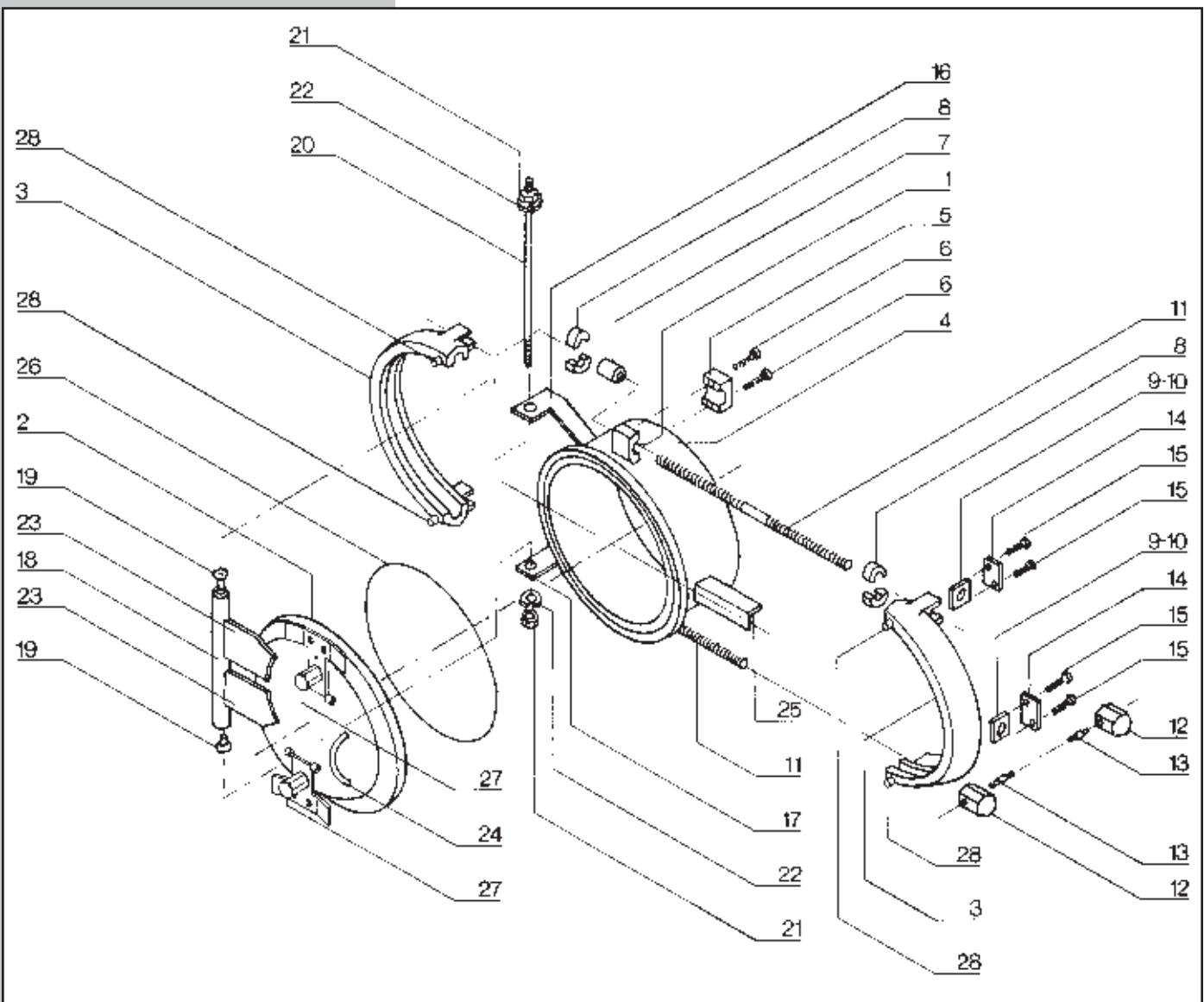

Spare Parts—It is suggested that the following spare parts be stocked for each closure:

Four O-Rings ..... Part No. 26

Two Yoke Bolt Units consisting of:

Part Nos ..... 7,8,9,10,11,12&13

When ordering spare parts, give amount, description, part number and size, pressure class and serial number of closure (located on front of yoke or ASME nameplate).

Example: (1) O-ring - Part Number 26 - 8" CL 600 - S/N 13845

# DOUBLE BOLT VERTICAL DIMENSIONS

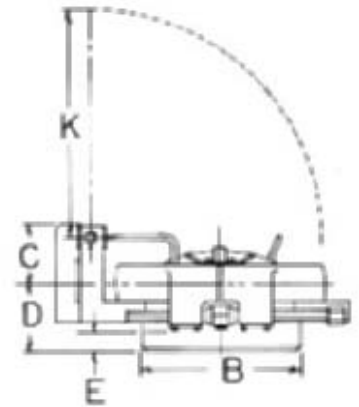
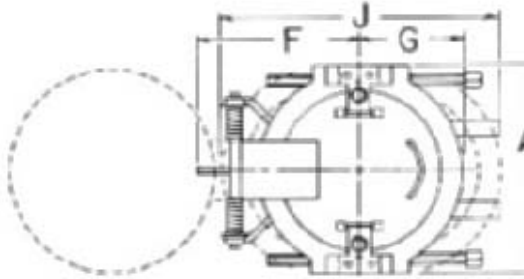
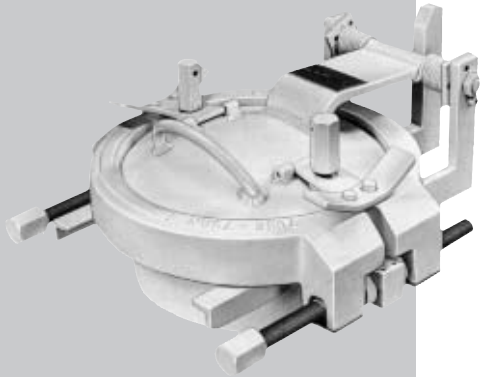

U.S. PAT. NO. 3,077,360

	Nominal Size	Over-all A	OD at Welding Bevel B	Back to Face Max. C	Hub Length D	Clear Hub Length E	Center to Hinge End F	Center to Free End G	Yoke Clearance J	Opening Clearance K	Approx. Weight Lbs
<b>Class 150-V Double Bolt Vertical</b>	8	12 11/16	8 5/8	4 3/16	4	5/8	9 9/16	5 1/2	15 1/8	12 1/16	60
	10	14 7/8	10 3/4	4 9/16	4 1/4	7/8	11 1/4	6 3/4	18 1/8	14 15/16	80
	12	16 7/8	12 3/4	4 3/8	4 1/4	13/16	12 9/16	7 3/4	20 7/16	17 1/4	110
	14	18 1/8	14	4 5/16	4 1/4	3/4	13 1/2	8 7/16	22	18 13/16	130
	16	20 7/8	16	4 13/16	4 5/8	11/16	14 1/4	9 1/2	24 15/16	19 5/8	170
	18	22 7/8	18	5 1/16	4 5/8	11/16	15 5/8	10 1/2	27 3/16	22 1/4	200
	20	24 7/8	20	6	4 5/8	5/8	16 3/4	11 1/2	29 7/16	24 1/16	230
	22	26 7/8	22	6 1/4	4 5/8	5/8	18 7/16	12 9/16	32 1/4	26 15/16	270
	24	28 7/8	24	6	4 5/8	5/8	19 5/8	13 5/8	34 5/8	28 1/16	320
	26	30 7/8	26	5 9/16	5	1/2	21 1/4	14 11/16	37 1/2	31	380
	28	32 7/8	28	6 5/8	5	7/16	23 7/16	15 3/4	40	32 3/4	450
	30	34 7/8	30	7 1/2	5 1/2	13/16	25 1/8	16 15/16	43 1/8	35 3/8	540
	32	37 5/8	32	9 1/2	5 1/2	1/2	29 1/8	18	45 9/16	37 1/8	620
	34	39 5/8	34	9 1/2	5 1/2	1/2	29 13/16	19	47 13/16	39 3/8	700
36	41 5/8	36	9 3/8	6	13/16	28 1/2	20 1/16	50 1/4	39 5/8	810	
38	44 1/8	38	9 3/8	6	3/4	29 3/4	21 1/8	52 9/16	42 1/8	910	
40	46 1/8	40	9 1/4	6	5/8	31 1/4	22 5/16	55 13/16	44 9/16	1030	
42	48 1/8	42	9 5/8	6 1/8	5/8	32 1/2	23 5/16	58 3/16	46 3/16	1200	
<b>Class 300-V Double Bolt Vertical</b>	8	12 11/16	8 5/8	4 3/16	4	5/8	9 9/16	5 1/2	15 1/8	12 1/16	60
	10	14 13/16	10 3/4	4 9/16	4 1/4	7/8	11 1/4	6 3/4	18 1/8	14 15/16	80
	12	16 13/16	12 3/4	4 1/2	4 1/4	15/16	12 9/16	7 3/4	20 13/16	17 1/4	120
	14	18 3/16	14	4 1/2	4 1/4	15/16	13 9/16	8 7/16	22 13/16	18 15/16	150
	16	20 15/16	16	7 13/16	5	1	15 1/16	9 1/2	25 7/8	19 13/16	180
	18	23 1/8	18	8 13/16	5 1/4	7/8	17 7/8	11 3/16	30 7/16	23 1/2	240
	20	25 1/4	20	8 1/4	5 5/8	11/16	18 11/16	12 5/16	33 1/8	25	320
	22	27 3/4	22	8 1/16	6 1/4	15/16	20	13 1/8	35 7/8	27 3/8	390
	24	30 9/16	24	8 1/2	6 1/2	7/8	22 9/16	14 11/16	38 9/16	29 7/8	490
	26	32 1/2	26	9 3/16	6 3/4	1 1/4	24 3/16	15 7/16	42 3/16	32 1/8	610
28	34 3/4	28	10 1/8	7 1/2	1 5/16	25 9/16	16 1/2	44 3/8	34 3/8	740	
30	36 7/8	30	10 1/2	7 3/4	1 7/16	27	17 11/16	47 11/16	36 1/4	890	

All dimensions are in inches. When ordering, please specify type, nominal size, bore, material and service conditions. Tube Turns Hinged Closures are regularly furnished in carbon steel; however, closures are also available in high yield strength steels. Closures are also available in other metals and alloys and in other sizes and pressure classes on special order. Lifting Eyes are provided on Vertical types when specified. Vertical Hinged Closures are furnished with spring-loaded heads. Heads counter-balanced by weights can be provided for larger sizes. They can be provided by Tube Turns on special orders. Chain-and Sprocket Drives are available at extra cost (see page 8). Attached Break-Over Wrenches are available at extra cost (see page 21). For Pressure-Temperature Ratings, see page 7

# DOUBLE BOLT VERTICAL DIMENSIONS

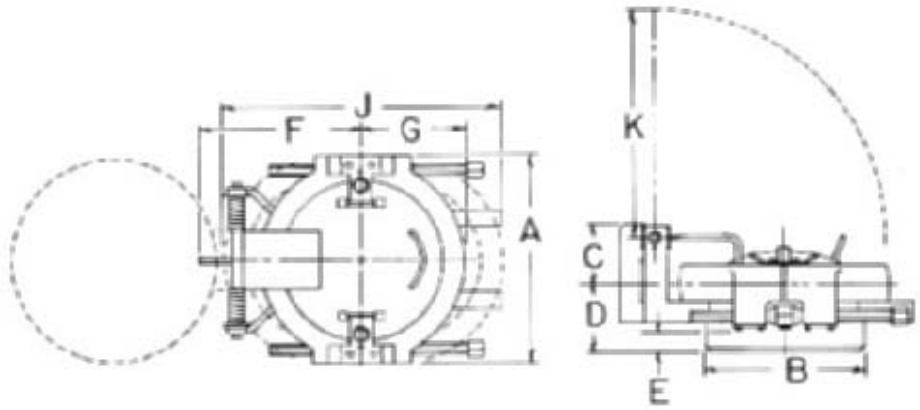
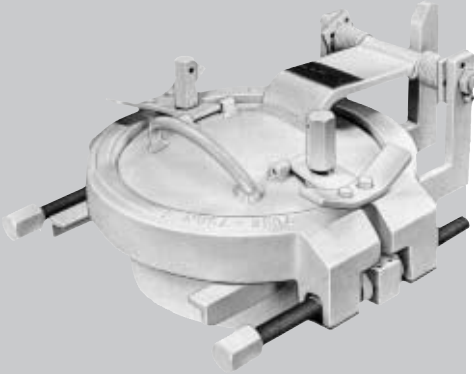

	Nominal Size	Over-all A	OD at Welding Bevel B	Back to Face Max. C	Hub Length D	Clear Hub Length E	Center to Hinge End F	Center to Free End G	Yoke Clearance J	Opening Clearance K	Approx. Weight Lbs
<b>Class 600-V Double Bolt Vertical</b>	8	12 3/4	8 5/8	4 1/2	4 1/4	5/8	10 3/16	5 15/16	16 7/8	12 15/16	90
	10	14 7/8	10 3/4	5 1/8	4 7/16	5/8	12 1/4	7 3/16	20 1/4	16	160
	12	17 5/8	12 3/4	5 13/16	5 3/16	3/8	13 3/16	8 1/4	22 5/8	16 1/16	190
	14	19	14	6 1/16	5 1/4	5/16	14 5/16	9	25 1/8	18 1/16	230
	16	21 7/8	16	7	6 1/16	9/16	17 1/16	10 11/16	29 3/8	21 3/4	360
	18	24 7/8	18	7 3/16	6 1/4	1/2	19 5/8	12 1/4	34	24 11/16	500
	20	27 1/8	20	11 11/16	7	3/8	21 7/8	13 1/2	37 1/4	28	840
	22	29 1/8	22	13 7/8	8	1 3/16	23 1/8	14 1/2	40	29 3/16	780
	24	32 1/8	24	12 1/4	8 3/8	1 3/16	23 3/4	15 3/8	42 3/4	31 1/4	930
	26	34 3/8	26	12 1/8	8 9/16	1 1/4	25 7/8	16 11/16	46 1/2	32 5/8	1160
28	36 1/16	28	12 3/4	8 3/4	1 5/16	27 3/4	17 7/8	49 7/8	35 9/16	1420	
30	38 9/16	30	13 3/8	9 1/2	1 3/8	29 3/4	19	52 3/4	35 3/4	1750	
<b>Class 900-V Double Bolt Vertical</b>	8	12 13/16	8 5/8	4 13/16	4 9/16	9/16	11 1/8	6 1/4	18 7/16	14 1/16	150
	10	15 15/16	10 3/4	7 1/16	5 7/8	1 1/16	12 15/16	7 3/4	22 1/4	16 5/16	230
	12	18 15/16	12 3/4	7 7/8	6 3/8	11/16	15 3/8	9 3/16	25 7/8	19 1/2	370
	14	20 1/2	14	8 1/8	6 5/8	13/16	16 1/8	9 15/16	28 1/16	20 1/8	470
	16	23	16	8 5/16	7 1/2	11/16	17 7/8	11 1/4	31 1/4	22 15/16	630
	18	25 1/16	18	9 1/2	7 13/16	1	20 1/2	12 1/4	35	25 13/16	930
	20	28 3/8	20	9 13/16	8 1/2	1 1/8	22 5/16	13 1/2	37 5/8	27 1/8	1230
	22	30 1/2	22	10 7/8	8 3/4	1 3/16	23 5/8	14 13/16	40 7/8	29 1/2	1620
24	33 1/8	24	13 1/2	9 1/2	1 1/4	25 1/4	16 1/8	44 1/2	32 3/4	2040	
<b>Class 1500-V Double Bolt Vertical</b>	10	17 1/8	10 3/4	8 11/16	7 1/2	1 3/8	14 3/8	8 3/8	24 1/2	17 1/2	400
	12	20 1/8	12 3/4	8 11/16	8 1/2	2 1/16	17	10	29 1/16	21 9/16	650
	14	21 5/8	14	8 3/16	8 3/4	1 5/8	19 3/16	10 3/4	30 3/4	23 3/8	800
	16	24 7/8	16	11 1/8	10	2 5/16	20 15/16	12 3/8	35	25 1/16	1200
	18	27 9/16	18	11 7/16	10 1/2	2 1/8	23	13 3/4	40	28 7/16	1600
	20	30 3/4	20	13	10 3/4	1 5/8	25 1/8	15 5/16	43 1/2	30 7/8	2200

All dimensions are in inches. When ordering, please specify type, nominal size, bore, material and service conditions. Tube Turns Hinged Closures are regularly furnished in carbon steel; however, closures are also available in high yield strength steels. Closures are also available in other metals and alloys and in other sizes and pressure classes on special order. Lifting Eyes are provided on Vertical types when specified. Vertical Hinged Closures are furnished with spring-loaded heads. Heads counter-balanced by weights can be provided for larger sizes. They can be provided by Tube Turns on special orders. Chain-and Sprocket Drives are available at extra cost (see page 8). Attached Break-Over Wrenches are available at extra cost (see page 21). For Pressure-Temperature Ratings, see page 7

# DOUBLE-BOLT VERTICAL PARTS

## Class V Double-Bolt Vertical Parts List

1. Hub	8. Collar	15. Cap Screws	22. Stop Arm	29. Adjusting Plate
2. Head	9. Nut (RH)	16. Hub Hinge Arm (RH)	23. Head Hinge Arm	30. Lock Screw
3. Yoke	10. Nut (LH)	17. Hub Hinge Arm (LH)	24. Head Handle	31. Pressure Warning Device And Positioning Plate
4. Bolt Holder (W)	11. Yoke Bolt	18. Hinge Tube	25. Support Arm	32. Positioning Lugs
5. Bolt Holder (L)	12. Wrench Lug	19. Hinge Bearing	26. O-Ring	
6. Cap Screws	13. Wrench Lug Pin	20. Hinge Rod	27. Spring (RH)	
7. Yoke Bolt Bushing	14. Cover Plate	21. Hinge Rod Nut	28. Spring (LH)	

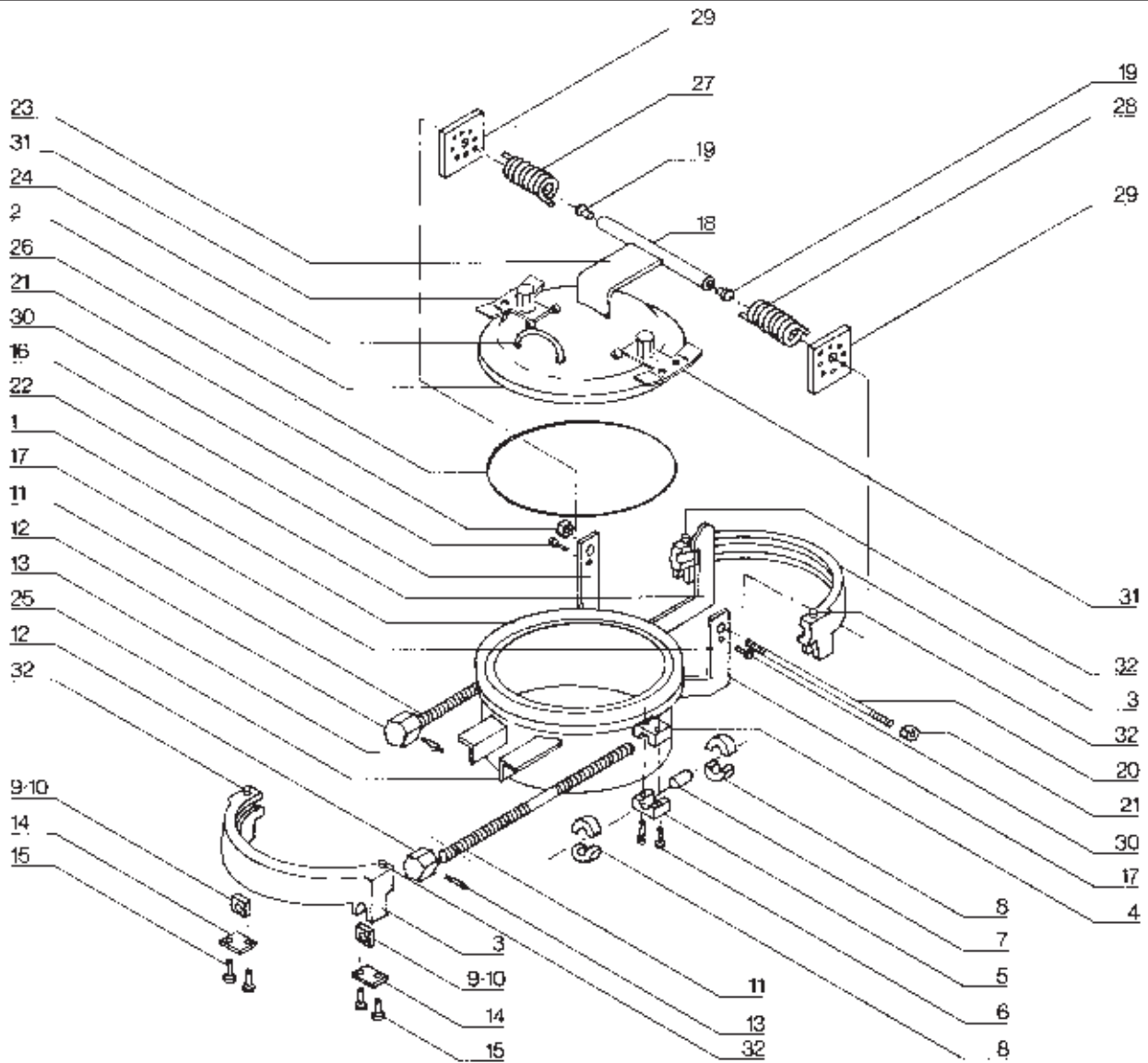

Spare Parts—it is suggested that the following spare parts be stocked for each closure:  
Four O-Rings

..... Part No. 26

Two Yoke Bolt Units consisting of:

Part Nos ..... 7,8,9,10,11,12&13

When ordering spare parts, give amount, description, part number and size, pressure class and serial number of closure (located on front of yoke or ASME name plate). Example: (1) O-ring - Part Number 26 - 8" CL 600 - S/N 13845



# SINGLE BOLT CLOSURE

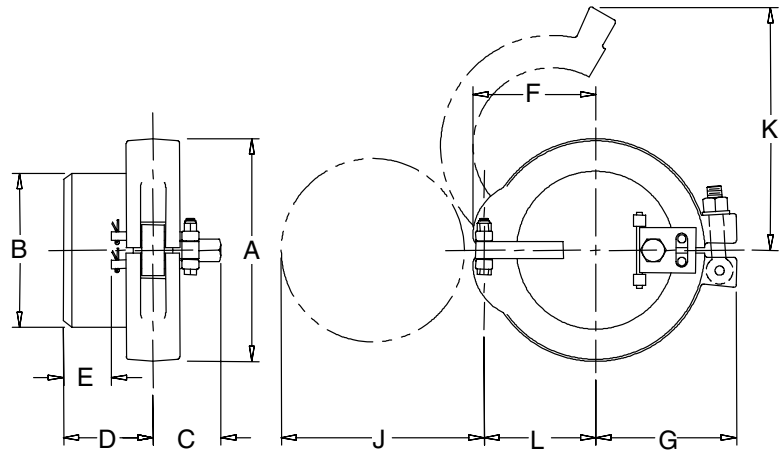
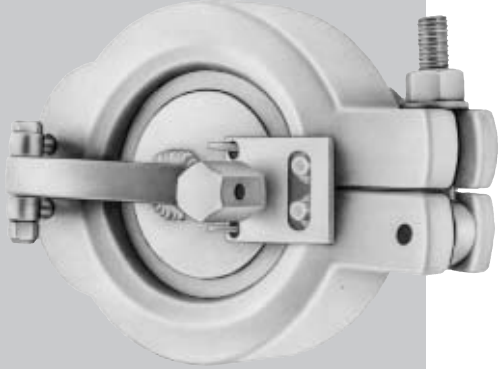

	Nominal Size	Over-all A	OD at Welding Bevel B	Back to Face Max. C	Hub Length D	Clear Hub Length E	Center to Head Stop F	Center to Free End G	Opening Clearance J	Yoke Clearance K	Center to Hinge L	Approx Weight Lbs
<b>Class 150-S, 300S, 600S Single Bolt</b>	2	4 7/8	2 3/8	2 3/4	3 1/8	1 9/16	2 5/8	3 5/8	4 1/16	6 1/8	2 1/4	10
	3	6 1/4	3 1/2	2 15/16	3 1/2	1 9/16	3 3/8	4 1/4	5 1/4	7 5/16	2 7/8	15
	4	7 3/8	4 1/2	3 1/8	4 1/4	2 7/16	4 13/16	5	6 9/16	8 5/16	3 11/16	25
	6	10	6 5/8	3 1/2	4 1/4	2 1/2	5 7/16	6 1/4	9	10 13/16	4 15/16	50
	8	11 15/16	8 5/8	4	4 1/4	2 1/16	6 3/8	7 3/8	10 3/4	13 11/16	5 3/4	70

All dimensions are in inches. When ordering, please specify type, nominal size, Bore, Material and service conditions. S-Bolt Closures are regularly furnished in carbon steel however, they are also available in other metals and alloys.

### *For small diameter piping*

Because of space limitations, it usually is impractical and uneconomical to use double-bolt Hinged Closures for blanking off small openings in pipe lines and processing equipment. Tube Turns regularly furnishes single-bolt designs in sizes 2" through 8". The single-bolt adaptation provides significant advantages in many applications. There is only one bolt to operate, for example, and operating time is further reduced. And when speed of operation is a paramount requirement, the swing bolt design affords even greater savings of time and effort. Such standard features as tapered-surface sealing, hinged-head convenience and O-ring economy are retained in the single-bolt design.

Tube-Turns Single-Bolt Closures are offered in these designs:

Type	Nominal Sizes	ASME Pressure Rating
150-S	2" - 8"	150 lb (285 psi)
300-S	2" - 8"	300 lb (740 psi)
600-S	2" - 8"	600 lb (1480 psi)

Carbon steel is the standard material of construction for Tube Turns Single-Bolt Closures, but they also can be furnished in stainless steels and other materials depending upon customer requirements.

# SINGLE BOLT CLOSURE PARTS

Class S/Swing Bolt Parts List			
1. Hub	6. Yoke (Upper)	10. Swing Bolt	15. Pressure Warning Device and Positioning Plate
2. Hub Hinge Lug	7. Yoke (Lower)	11. Swing Bolt Nut	16. Positioning Lugs
3. Head	8. Hinge Eye Bolt	12. Swing Bolt Pin	17. Washer
4. Hinge Arm	9. Cotter Pin (2" thru 6")	13. O-Ring	
5. Hinge Bolt	9A. Eye Bolt Nut (8")	14. Hinge Bolt Nut	

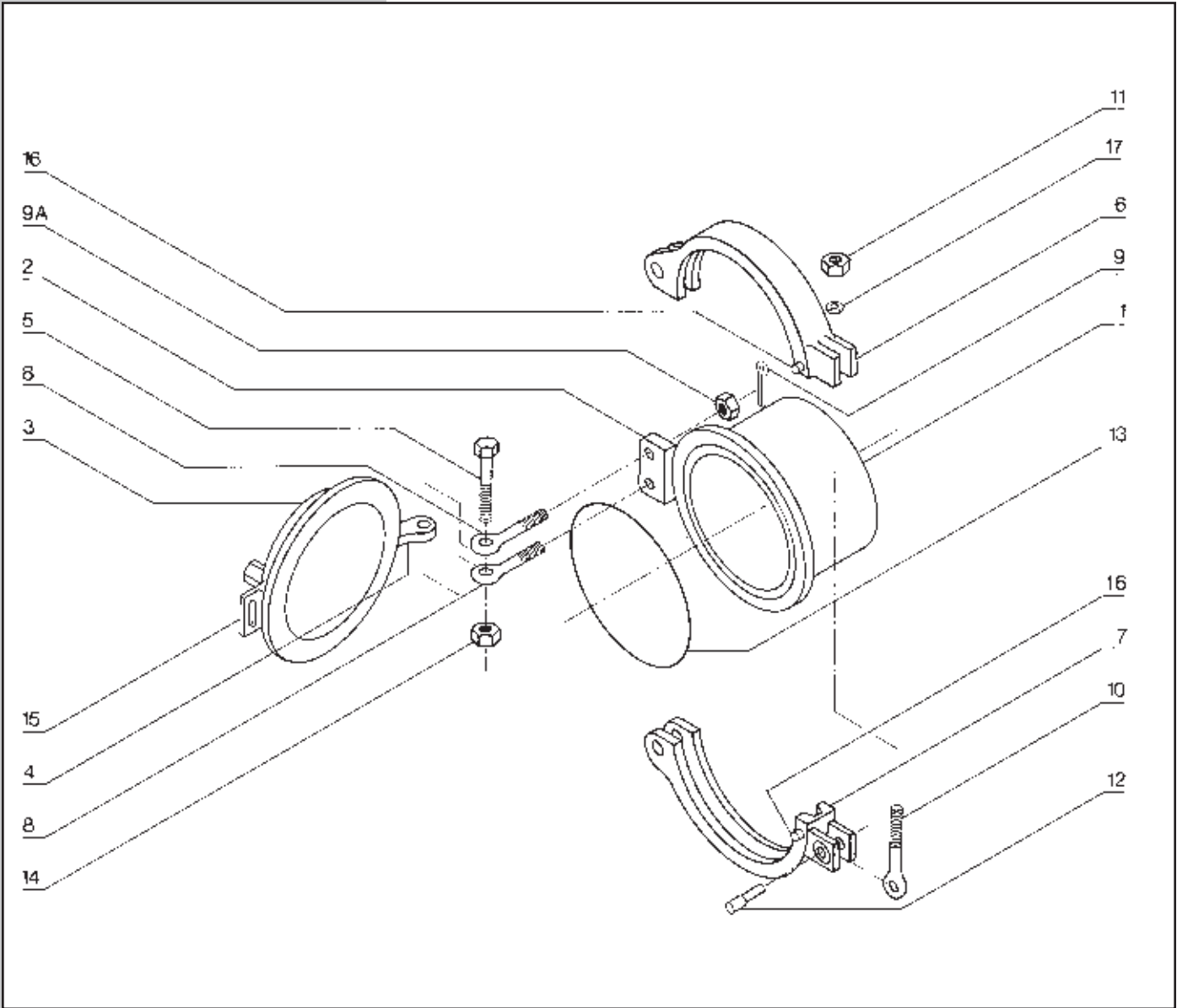

**Spare Parts**—It is suggested that the following spare parts be stocked for each closure:

Four O-Rings ..... Part No. 13

When ordering spare parts, give amount, description, part number and size, pressure class and serial number of closure (located on front of yoke or ASME nameplate). Example: (1) O-ring - Part Number 13 - 8" CL600 - S/N 13845



# PRESSURE WARNING DEVICE

## Pressure Warning Device Parts List

- |                |                      |
|----------------|----------------------|
| 1. Holding Nut | 5. Positioning Plate |
| 2. Gasket      | 6. Hinge Pin         |
| 3. Nipple      | 7. Hinge             |
| 4. Plate Stop  | 8. Positioning Lugs  |

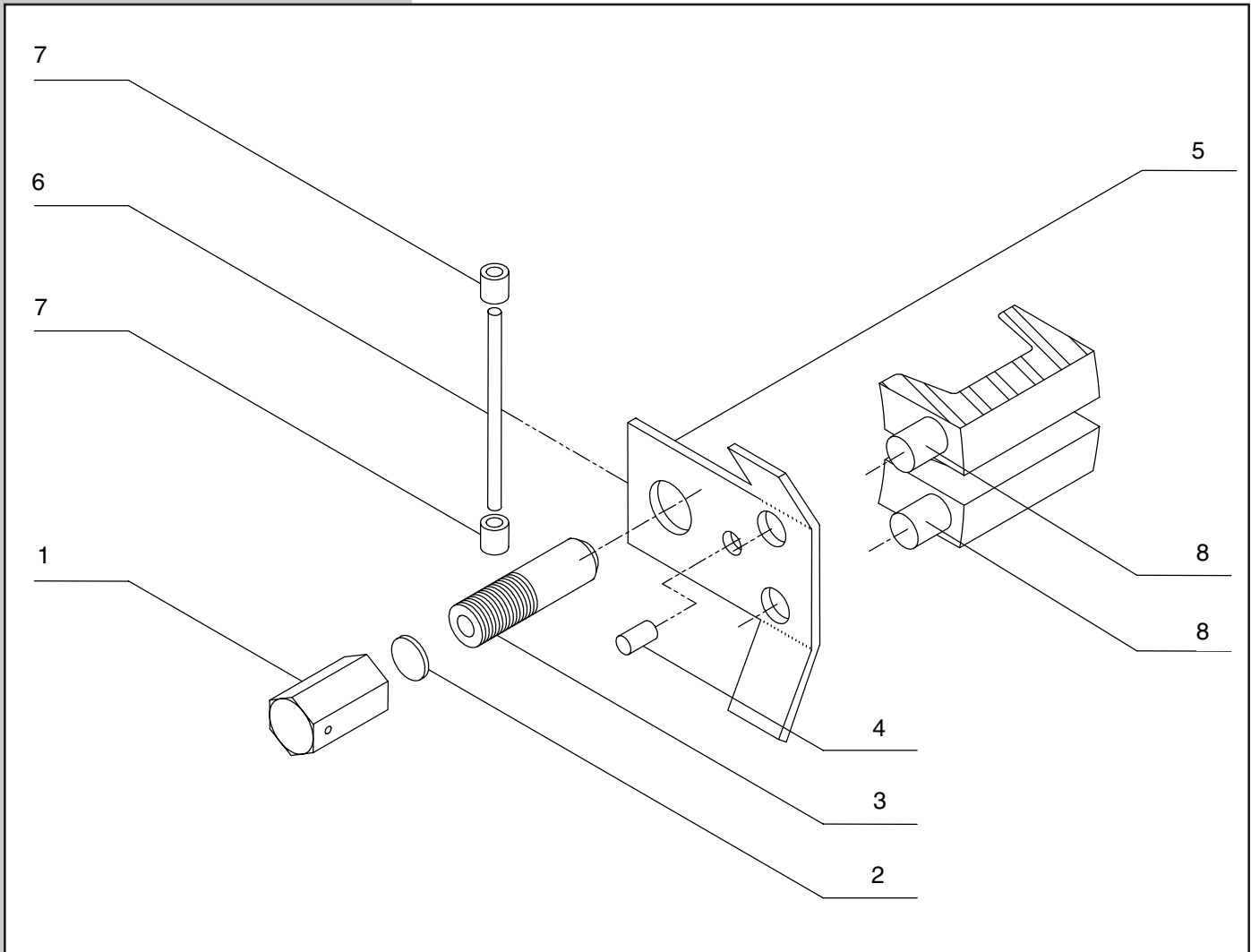

# T-BOLT STYLE CLOSURES

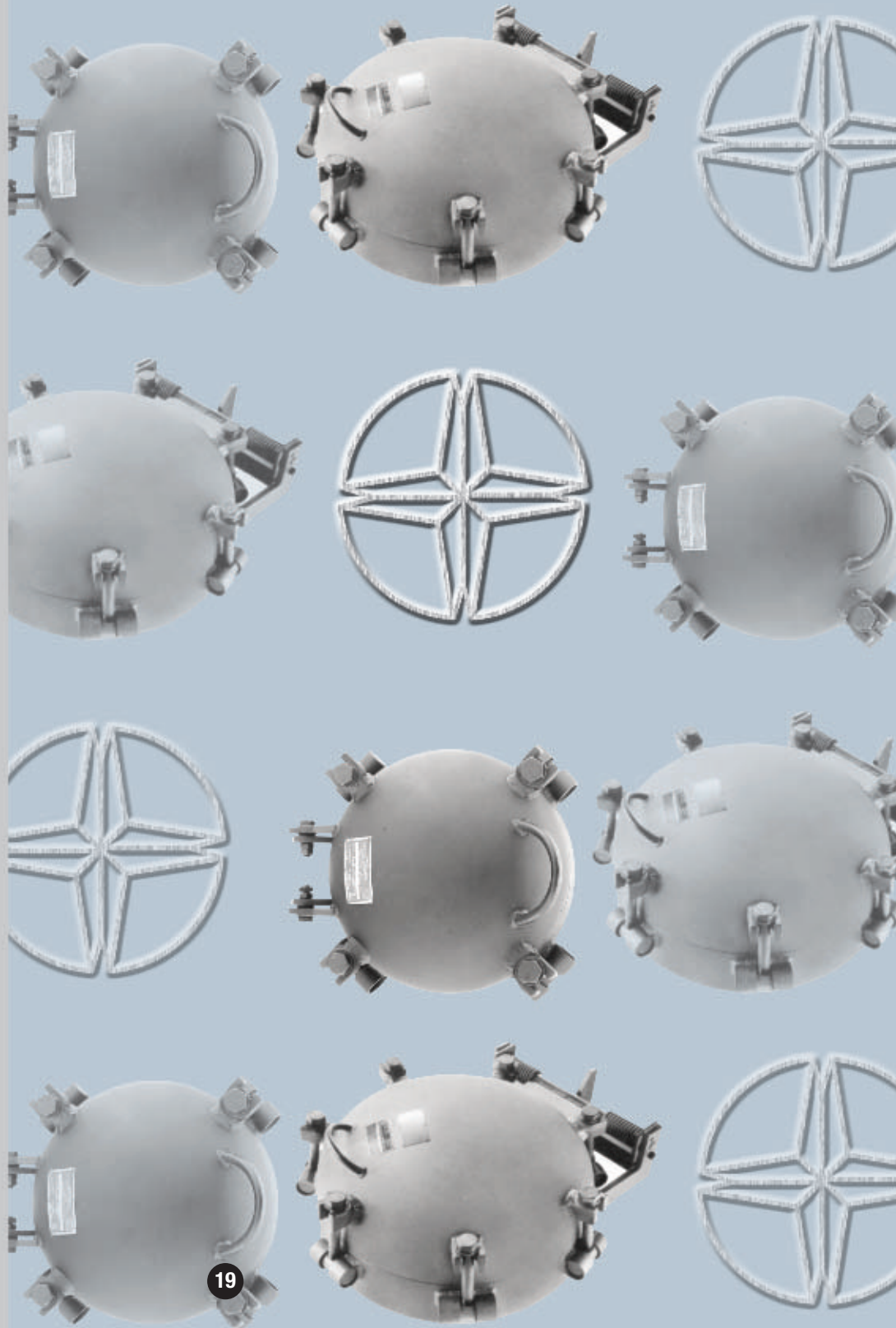

# T-BOLT HINGED CLOSURES

## GENERAL INFORMATION

Tube Turns' exclusive T-Bolt Closure is designed expressly for nominal pressure applications. Less expensive and much more satisfactory than blind flanges and job-fabricated closure devices, it is ideal for:

1. Manways for storage tanks, mixing vessels, filters, separators and other batch equipment.
2. Caps for inspection ports and other access openings on towers and reactors.
3. Handholes on processing equipment and medical or laboratory apparatus such as hyperbaric chambers.

### Economically Priced

Low initial cost is an especially attractive feature of the Tube Turns T-Bolt Closure. A complete unit normally costs less than the component parts for a blind and slip-on flange combination. There are no additional expenses for hinges, hoists, davits, etc., as the closure is fully assembled when shipped. Furthermore, installation and labor charges are held to a minimum; a single butt weld joins the closure to the nozzle vessel.

### Compact Design

Simplicity of construction and operation are keynotes of the Tube Turns T-Bolt Hinged Closure. The closure consists of a thick semi-ellipsoidal head that is hinged to a matching hub, a self energized O-ring and a suitable number of T-Bolts to effect and maintain a tight seal. For most services, the standard materials—carbon steel and a "Buna-N" O-ring are satisfactory. Other metals and elastomers are furnished on special request. The T-Bolt Hinged Closure is opened quickly and easily. The operator merely loosens the T-Bolts until they clear the head lugs and allow the head to be swung open on its hinge. Complete, unrestricted access is provided, too, since the standard hinging permits a full 180° opening.

### Warning Feature

The holding lugs are mounted on the closure head at an angle of approximately 10°. This provides a valuable feature, for the angular mounting requires that the T-bolt be backed off an extra turn or two before it will swing out of the holding position.

Thus, if there is pressure in the vessel while it is being opened, initial turns of the

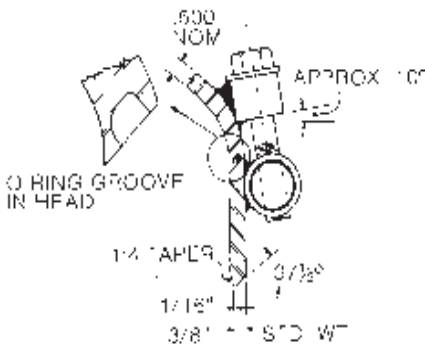

bolts permit the head to lift slightly and the contained fluid escapes, alerting the operator to possible danger. Further movement of the head is restrained, since the T-bolt is confined within the holding lug.

### Operating Savings

Tube Turns T-Bolt Hinged Closures provide savings of time and labor. The semi-ellipsoidal shape of the T-Bolt Closure has greater pressure-holding capacity than a flat plate of equal thickness. This permits substantial weight reduction: the head of a 24" T-Bolt Closure, for instance, weighs only 100 pounds, as compared with 410 pounds for a comparable size 150 lb blind flange. *And the mechanical advantage afforded by the hinge arrangement further reduces the force needed to open a T-Bolt Closure.* Bolting is also simplified. A 24" T-Bolt Closure has but five bolts, while the same size 150 lb flange requires 20. Furthermore, the T-bolts remain attached to the closure when it is opened, eliminating possibilities of dropped or misplaced nuts, bolts and washers.

### Full Size Range

Standard Tube Turns T-Bolt Hinged Closures are furnished in carbon steel, stainless steel, & other alloys. Sizes range from 6" thru 66".



# T-BOLT HINGED CLOSURES

## T-BOLT CLOSURE OPTIONS

Break-Over Wrenches and Camlocks are optional attachments and accessories adding further to the versatility and utility of our T-Bolt Closures. Attachment of either of these options to the closure's T-Bolts provides extra convenience, speed and ease in tightening the bolts. These attachments eliminate the need for separate wrenches.

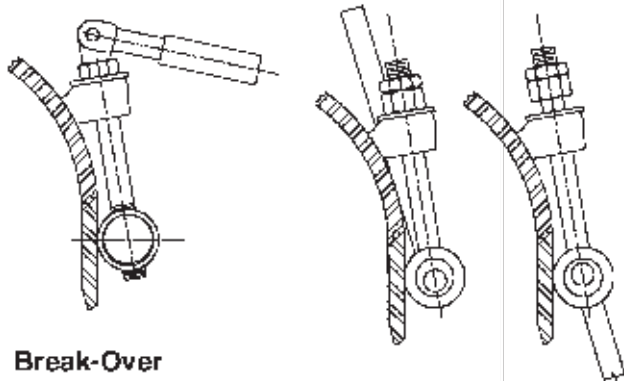

**Break-Over Wrench Assembly**

**Tightened Loosened Camlock Assembly**

The Break-Over Wrench Lug is welded to the T-Bolt (head bolt) and a handle is inserted over this lug. A pin is then inserted through the handle and the lug allowing the handle to act as a wrench and making the Break-Over Wrench an integral part of the T-Bolt Assembly.

In a Camlock Assembly, components replace the tapped swing nut (in the hub nut mount). The Camlock bolting unit consists of a high strength eye bolt that is pinned through an eccentric cam to provide the necessary clamping action. The camming action is adjustable by moving the adjustable nut at the threaded end of the eye bolt. This allows the camlock assembly to be loosened & tightened merely by lowering or raising the cam handle.



## Vertical T-Bolt Closures

T-Bolt Closures with a spring loaded head for vertical applications are furnished in sizes 10" - 42". The need for spring loading can be determined by reference to the table below. The tabulated "Force to Lift Head" is the force to lift the head **without** the springs.

Closure Size	6	8	10	12	14	16	18	20	22	24	26	28	30	32	34	36	38	40	42
Weight of Head (lbs)	7	12	19	22	32	41	53	67	74	100	112	125	139	169	184	269	295	322	346
Force to Lift Head (lbs)	4	9	12	15	20	26	32	40	44	58	62	71	76	90	106	149	168	186	231

# T-BOLT RATINGS

Closure Size	Class 75		Class 150		Class 300	
	Carbon Steel	Stainless Steel**	Carbon Steel	Stainless Steel**	Carbon Steel	Stainless Steel**
6	-	-	320	320	510	510
8	-	-	185	185	390	390
10	115	115	245	245	365	365
12	170	170	255	255	380	380
14	140	140	210	210	365	365
16	105	105	185	185	385	380
18	125	125	185	185	375	365
20	100	100	175	175	355	345
22	100	100	200	195	330	320
24	115	105	190	190	310	305
26	115	105	180	180	265	255
28	110	100	190	190	255	245
30	105	95	180	180	240	235
32	100	90	175	160	210	190
34	150	135	170	165	205	200
36	120	110	165	160	185	180
38	125	115	175	170	-	-
40	105	95	170	165	-	-
42	110	100	165	160	-	-
48	120	120	135	130	-	-

\*\* Ratings apply to stainless steel closures with carbon steel bolts and attachments. Closures of all stainless steel are rated lower. For temperatures higher than 450F, consult Tube Turns stating temperature, pressure, fluid and type of o-ring required. Ratings apply for closures with ASME SA325 bolts. Slightly higher ratings are available in some sizes upon application by using ASME SA193 Grade B7 bolts, resulting in a slightly higher price.

Above ratings good for 450F. "Buna-N" is the standard O-ring gasket material. For services above 250F or where special corrosive conditions are to be encountered, O-rings of "Viton", Silicone Rubber, "Neoprene" Ethylene Propylene, "Teflon Encapsulated" (Viton or Silicone Core) can be furnished at an extra charge. Refer to Page 7

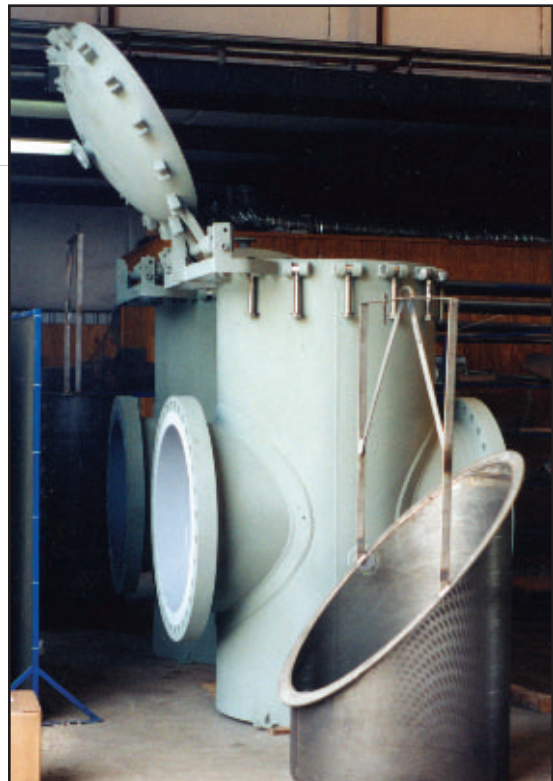

# T-BOLT HORIZONTAL DIMENSIONS

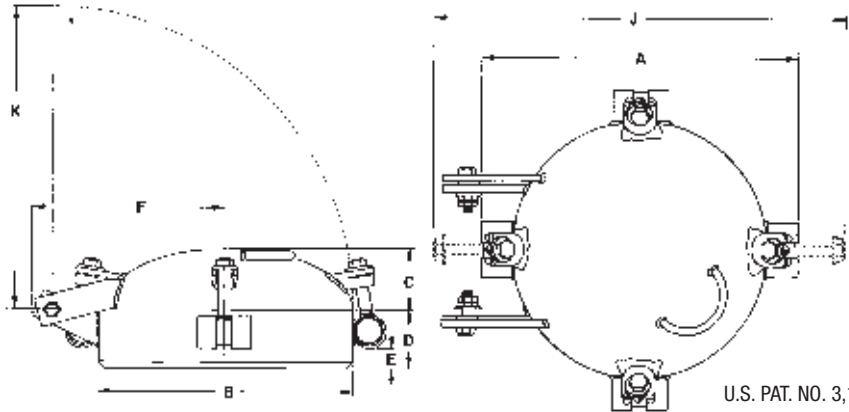
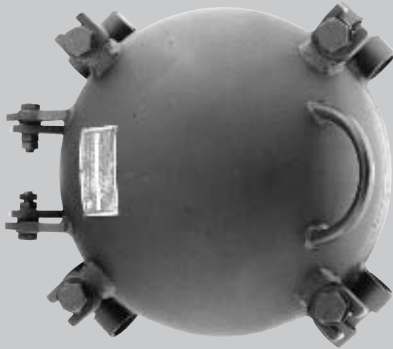

U.S. PAT. NO. 3,187,929

	Nom. Pipe Size	Nom.* Wall Thickness	Over-all A	OD at Welding Bevel B	Back to Face C	Hub Length D	Clear Hub Length E	Center to Hinge End F	Swing Bolt Clearance J	Opening Clearance K	No. Bolts	Bolt Size	Approx. Weight Lbs
<b>Class 75-TB T-Bolt Horizontal</b>	10	.500	13 3/8	10 3/4	2 13/16	2 1/2	1 1/16	7 5/8	18	12 1/4	3	1/2	30
	12	.500	16 1/8	12 3/4	3 1/8	2 5/8	3/4	8 15/16	21	14 1/4	4	5/8	50
	14	.500	17 3/8	14	3 9/16	2 7/8	1	9 9/16	22	15 1/2	4	5/8	60
	16	.500	19 3/8	16	4	2 7/8	1	10 1/2	24	17 1/2	4	5/8	70
	18	.500	21 3/8	18	4 1/2	3 3/8	1 3/8	11 11/16	30	19 1/2	4	3/4	95
	20	.500	23 3/8	20	4 15/16	3 7/8	1 7/8	12 15/16	32	21 11/16	4	3/4	115
	22	.500	25 3/8	22	5 1/4	4 3/8	2 3/8	13 15/16	34	23 11/16	5	3/4	140
	24	.500	27 7/8	24	5 3/4	4 3/8	1 13/16	15	38	25 11/16	5	7/8	165
	26	.500	29 7/8	26	6 1/4	4 3/8	1 13/16	16 1/4	40	28	6	7/8	180
	28	.500	31 7/8	28	6 3/4	4 3/8	2 1/8	17 1/4	42	30	7	7/8	200
	30	.500	33 7/8	30	7 1/4	4 3/8	1 7/8	18 5/16	45	32	8	7/8	230
	32	.500	35 7/8	32	7 3/4	4 3/8	2	19 5/8	47	34	9	7/8	265
	34	.625	38 3/4	34	8 3/16	4 3/8	1 5/16	20 5/8	51	36	9	1 1/8	325
	36	.625	40 3/4	36	8 11/16	4 1/2	1 5/8	21 9/16	53	38	9	1 1/8	410
	38	.625	42 3/4	38	9 3/16	4 1/2	1 5/8	22 9/16	55	40	10	1 1/8	450
	40	.625	44 3/4	40	9 11/16	4 1/2	1 5/8	22 3/4	57	42	10	1 1/8	480
42	.625	46 3/4	42	10 3/16	4 1/2	1 5/8	25 5/16	61	44 3/4	11	1 1/8	550	
48	.750	52 3/4	48	11 3/4	7	4 1/8	28 1/8	67	49 1/2	14	1 1/8	830	
<b>Class 150-TB T-Bolt Horizontal</b>	6	.500	9 1/4	6 5/8	2 1/8	1 11/16	1/4	5 1/2	13	8	3	1/2	15
	8	.500	11 1/4	8 5/8	2 3/16	2 1/4	13/16	6 5/8	15	10 1/8	3	1/2	20
	10	.500	14 1/8	10 3/4	2 13/16	2 1/2	3/4	7 5/8	19	12 1/4	4	5/8	35
	12	.500	16 1/8	12 3/4	3 1/8	2 5/8	3/4	9	23	14 5/16	4	3/4	55
	14	.500	17 3/8	14	3 9/16	2 7/8	1	9 9/16	24	15 1/2	4	3/4	65
	16	.500	19 3/8	16	4	2 7/8	1	10 1/2	26	17 1/2	7	5/8	80
	18	.500	21 3/8	18	4 1/2	3 3/8	1 3/8	11 11/16	30	19 1/2	6	3/4	100
	20	.500	23 3/8	20	4 15/16	3 7/8	1 7/8	12 15/16	32	21 11/16	7	3/4	125
	22	.500	25 3/4	22	5 1/4	4 3/8	1 13/16	15 1/2	36	23 3/16	7	7/8	150
	24	.500	27 7/8	24	5 3/4	4 3/8	1 7/8	15	38	25 11/16	8	7/8	180
	26	.500	29 7/8	26	6 1/4	4 3/8	1 13/16	16 1/4	40	28	9	7/8	200
	28	.500	31 7/8	28	6 3/4	4 3/8	2 1/8	17 1/4	43	30	11	7/8	225
	30	.500	33 7/8	30	7 1/4	4 3/8	1 7/8	18 5/16	45	32	12	7/8	250
	32	.500	36 3/4	32	7 3/4	4 3/8	1 5/16	19 5/8	49	34	10	1 1/8	310
	34	.625	38 3/4	34	8 3/16	4 3/8	1 5/16	20 5/8	53	36	10	1 1/8	380
	36	.625	40 3/4	36	8 11/16	4 1/2	1 5/8	21 9/16	55	38	11	1 1/8	460
38	.625	42 3/4	38	9 3/16	4 1/2	1 5/8	22 9/16	59	40 1/16	13	1 1/8	500	
40	.625	44 3/4	40	9 11/16	4 1/2	1 5/8	26 1/16	57	44 7/16	14	1 1/8	550	
42	.625	46 3/4	42	10 3/16	4 1/2	1 5/8	25	61	44 7/16	15	1 1/8	600	
48	.750	52 3/4	48	11 3/4	7	4 1/8	28	67	52	16	1 1/8	860	

All dimension are in inches. When ordering, please specify class, nominal size, bore, material and service conditions. T-Bolt Closures with longer hubs; Closures made to I.D. dimensions; or Closures equipped with Sight Glasses, Break-over Wrenches, Camlocks and other accessories are available on special order. \*Standard Closures are taper bored to match standard wall thickness.



# T-BOLT HORIZONTAL DIMENSIONS

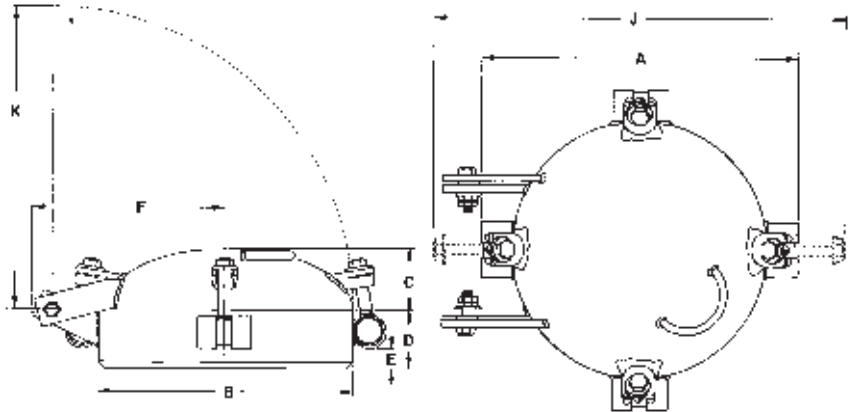
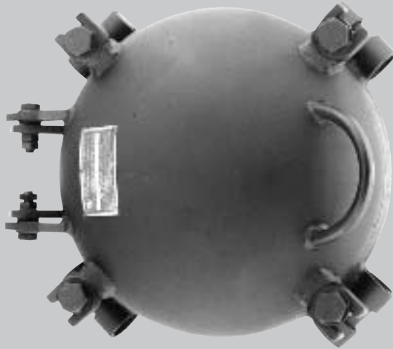

	Nom. Pipe Size	Nom.* Wall Thickness	Over-all A	OD at Welding Bevel B	Back to Face C	Hub Length D	Clear Hub Length E	Center to Hinge End F	Swing Bolt Clearance J	Opening Clearance K	No. Bolts	Bolt Size	Approx. Weight Lbs
<b>Class 300-TB T-Bolt Horizontal</b>	6	.500	9 7/8	6 5/8	2 1/8	2 1/16	5/16	5 5/8	16	8 1/8	3	5/8	18
	8	.500	11 7/8	8 5/8	2 3/16	2 1/4	7/16	6 9/16	19	10 1/8	4	5/8	27
	10	.500	14 1/8	10 3/4	2 13/16	2 1/2	5/8	7 5/8	20	12 1/4	4	3/4	35
	12	.500	16 1/8	12 3/4	3 1/8	2 5/8	3/4	9 3/4	23	15 3/16	6	3/4	55
	14	.500	17 3/8	14	3 9/16	2 7/8	1	9 1/2	25	15 7/8	7	3/4	70
	16	.500	19 7/8	16	4	2 7/8	3/8	10 1/8	29	17 1/2	7	7/8	85
	18	.500	22 3/4	18	4 1/2	3 3/8	5/8	11 3/4	33	20	6	1 1/8	130
	20	.500	24 3/4	20	4 15/16	3 7/8	1 1/8	12 5/16	36	21 9/16	7	1 1/8	175
	22	.500	26 3/4	22	5 1/4	4 3/8	1 5/8	13 15/16	38	23 11/16	8	1 1/8	200
	24	.500	28 3/4	24	5 3/4	4 3/8	1 5/8	16	40	26 11/16	9	1 1/8	230
	26	.500	30 3/4	26	6 1/4	4 3/8	1 1/4	16 5/8	42	28 5/8	9	1 1/8	250
	28	.500	32 3/4	28	6 3/4	4 3/8	1 5/8	17 5/16	45	30	10	1 1/8	275
	30	.500	34 3/4	30	7 1/4	4 3/8	1 11/16	18 5/16	47	32	11	1 1/8	300
	32	.500	36 3/4	32	7 3/4	4 3/8	1 5/16	19 11/16	49	34 7/16	11	1 1/8	360
	34	.625	38 3/4	34	8 3/16	4 3/8	1 5/16	21 1/8	53	36 1/2	12	1 1/8	440
	36	.625	40 3/4	36	8 11/16	4 1/2	1 5/8	25 5/16	55	38 3/4	12	1 1/8	510

All dimension are in inches. When ordering, please specify class, nominal size, bore, material and service conditions. T-Bolt Closures with longer hubs; Closures made to I.D. dimensions; or Closures equipped with Sight Glasses, Break-over Wrenches, Camlocks and other accessories are available on special order. \*Standard Closures are taper bored to match standard wall thickness.



We stock T-Bolt Closures in many sizes, pressure classes and materials.

# T-BOLT VERTICAL DIMENSIONS

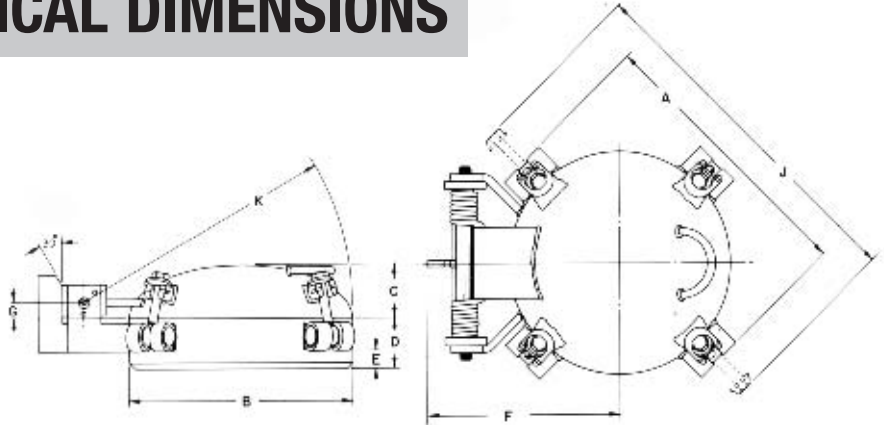

	Nom. Pipe Size	Nom.* Wall Thickness	Over-all A	OD at Welding Bevel B	Back to Face C	Hub Length D	Clear Hub Length E	Center to Hinge End F	Face to Hinge G	Swing Bolt Clearance J	Opening Clearance K	No. Bolts	Bolt Size	Approx. Weight Lbs
<b>Class 75-TBV T-Bolt Vertical</b>	10	.500	13 3/8	10 3/4	2 13/16	2 1/2	1 1/16	8 1/4	1 3/8	18	1 11/16	3	1/2	35
	12	.500	16 1/8	12 3/4	3 1/8	2 5/8	3/4	9 7/8	1 1/2	21	13 15/16	4	5/8	55
	14	.500	17 3/8	14	3 9/16	2 7/8	1	10 1/4	1 1/2	22	15 1/16	4	5/8	65
	16	.500	19 3/8	16	4	2 7/8	1	11 1/4	1 1/2	24	17 1/16	4	5/8	75
	18	.500	21 3/8	18	4 1/2	3 3/8	1 3/8	13 5/8	1 7/16	30	20 1/16	4	3/4	105
	20	.500	23 3/8	20	4 15/16	3 7/8	1 7/8	14 3/4	1 11/16	32	22 1/16	4	3/4	130
	22	.500	25 3/8	22	5 1/4	4 3/8	2 3/8	17 1/4	2 1/4	34	25 9/16	5	3/4	160
	24	.500	27 7/8	24	5 3/4	4 3/8	1 13/16	19 3/8	1 3/4	38	28 5/16	5	7/8	190
	26	.500	29 7/8	26	6 1/4	4 3/8	1 13/16	21 1/4	1 7/8	40	31 1/4	6	7/8	200
	28	.500	31 7/8	28	6 3/4	4 3/8	2 1/8	23	2 1/8	42	33 13/16	7	7/8	225
	30	.500	33 7/8	30	7 1/4	4 3/8	1 7/8	23	1 7/8	45	35 1/16	8	7/8	260
	32	.500	35 7/8	32	7 3/4	4 3/8	2	23	2	47	36 1/16	9	7/8	295
	34	.625	38 3/4	34	8 3/16	4 3/8	1 5/16	25 1/4	2 5/16	51	38 9/16	9	1 1/8	365
	36	.625	40 3/4	36	8 11/16	4 1/2	1 5/8	27	2 1/2	53	41 1/16	9	1 1/8	480
38	.625	42 3/4	38	9 3/16	4 1/2	1 5/8	28	2 1/2	55	43 1/16	10	1 1/8	515	
40	.625	44 3/4	40	9 11/16	4 1/2	1 5/8	28 13/16	2 7/8	57	45 1/16	10	1 1/8	550	
42	.625	46 3/4	42	10 3/16	4 1/2	1 5/8	30 7/16	2 7/8	61	47 1/16	11	1 1/8	630	
<b>Class 150-TBV T-Bolt Vertical</b>	10	.500	14 1/8	10 3/4	2 13/16	2 1/2	3/4	9 7/8	1 1/8	19	13 1/2	4	5/8	35
	12	.500	16 1/8	12 3/4	3 1/8	2 5/8	3/4	10 7/8	1 1/2	23	14 7/8	4	3/4	60
	14	.500	17 3/8	14	3 9/16	2 7/8	1	10 1/4	1 1/2	24	15	4	3/4	70
	16	.500	19 3/8	16	4	2 7/8	1	13 13/16	1 1/2	26	19 3/16	7	5/8	85
	18	.500	21 3/8	18	4 1/2	3 3/8	1 3/8	14 3/8	1 5/8	30	20 1/2	6	3/4	110
	20	.500	23 3/8	20	4 15/16	3 7/8	1 7/8	15 7/8	1 1/8	32	22 1/2	7	3/4	140
	22	.500	25 3/4	22	5 1/4	4 3/8	1 13/16	19 3/8	1 1/4*	36	25 1/2	7	7/8	170
	24	.500	27 7/8	24	5 3/4	4 3/8	1 7/8	19 3/8	2	38	28 1/4	8	7/8	205
	26	.500	29 7/8	26	6 1/4	4 3/8	1 13/16	22 1/4	2 1/8	40	31 5/8	9	7/8	225
	28	.500	31 7/8	28	6 3/4	4 3/8	2 1/8	23	2 1/8	43	33 3/4	11	7/8	250
	30	.500	33 7/8	30	7 1/4	4 3/8	1 7/8	27	1 3/8*	45	35	12	7/8	280
	32	.500	36 3/4	32	7 3/4	4 3/8	1 5/16	25	2	49	37	10	1 1/8	340
34	.625	38 3/4	34	8 3/16	4 3/8	1 5/16	27 7/8	1 3/4*	53	38 1/2	10	1 1/8	420	
36	.625	40 3/4	36	8 11/16	4 1/2	1 5/8	29 1/2	1 3/4*	55	41	11	1 1/8	530	
<b>Class 300-TBV T-Bolt Vertical</b>	10	.500	14 1/8	10 3/4	2 13/16	2 1/2	5/8	9 7/8	1 1/8	20	13 1/2	4	3/4	40
	12	.500	16 1/8	12 3/4	3 1/8	2 5/8	3/4	12 5/8	1 3/8	23	16 3/8	6	3/4	65
	14	.500	17 3/8	14	3 9/16	2 7/8	1	12 3/8	1 1/2	25	17 1/4	7	3/4	75
	16	.500	19 7/8	16	4	2 7/8	3/8	13 7/8	1 1/2	29	19 1/2	7	7/8	90
	18	.500	22 3/4	18	4 1/2	3 3/8	5/8	16 3/4	1	33	23	6	1 1/8	120
	20	.500	24 3/4	20	4 15/16	3 7/8	1 1/8	18 5/8	1 1/2	36	26	7	1 1/8	145
	22	.500	26 3/4	22	5 1/4	4 3/8	1 5/8	20	2 3/8	38	27 5/8	8	1 1/8	180
	24	.500	28 3/4	24	5 3/4	4 3/8	1 5/8	20 1/4	1 7/8	40	28 7/8	9	1 1/8	210
	26	.500	30 3/4	26	6 1/4	4 3/8	1 1/4	20 3/4	2 1/8	42	31 1/2	9	1 1/8	230
	28	.500	32 3/4	28	6 3/4	4 3/8	1 5/8	22 3/4	2 1/8	45	33 3/4	10	1 1/8	260
	30	.500	34 3/4	30	7 1/4	4 3/8	1 11/16	23 5/8	1 3/8	47	35 1/4	11	1 1/8	290
	32	.500	36 3/4	32	7 3/4	4 3/8	1 5/16	25	1 5/8	49	37 1/4	11	1 1/8	350
34	.625	38 3/4	34	8 3/16	4 3/8	1 5/16	26 1/2	1 1/2	53	39 1/2	12	1 1/8	435	
36	.625	40 3/4	36	8 11/16	4 1/2	1 5/8	27 1/2	2 1/8	55	41 1/2	12	1 1/8	540	

All dimension are in inches. When ordering, please specify class, nominal size, bore, material and service conditions. T-Bolt Closures with longer hubs; Closures made to I.D. dimensions; or Closures equipped with Sight Glasses, Break-over Wrenches, Camlocks and other accessories are available on special order. \*Standard Closures are taper bored to match standard wall thickness.



# T-BOLT CLOSURE PARTS

## T-Bolt Closure Horizontal Parts List

1. Head Handle	4. Hinge Bushings	7. Hub	10. Tapped Swing Nut	13. Hinge Bolt Washer
2. Head Bolt Lug	5. Head Hinge Arm	8. Head Bolt	11. Hub Nut Mounts	14. Hinge Bolt
3. Head	6. O-Ring	9. Head Bolt Washer	12. Hinge Bolt Nut	15. Hub Hinge Arms

## T-Bolt Closure Vertical Parts List

1. Head Handle	6. O-ring	11. Hub Nut Mounts	16. Adjusting Plate	21. Hinge Brace
2. Head Bolt Lug	7. Hub	12. Hinge Tube	17. Lock Screw	
3. Head	8. Head Bolt	13. Spring (R.H.)	18. Head Stop	
4. Hinge Bushing	9. Head Bolt Washer	14. Spring (L.H.)	19. Hinge Rod	
5. Head Hinge Arm	10. Tapped Swing Nut	15. Hub Hinge Arms	20. Hinge Rod Set Screw	

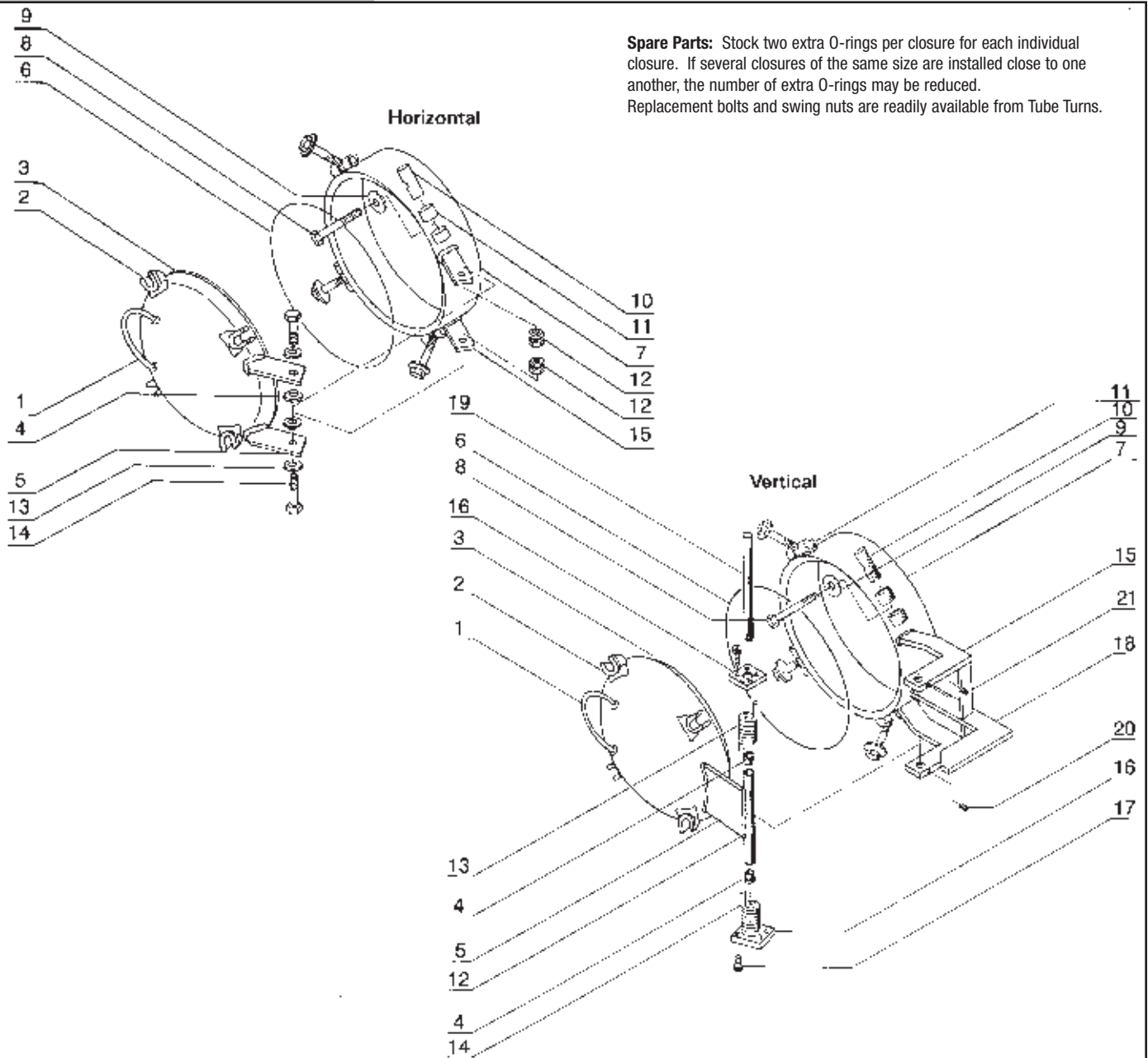

# TERMS AND CONDITIONS

1. Seller offers to sell to Buyer, or accepts Buyer's offer to purchase, on the condition that Buyer assents to the terms contained herein. Buyer's failure to provide seller with notification of any objection to these terms within a period of five days after receipt of this instrument or Buyer's acceptance of any product shipped hereunder constitutes assent by the Buyer to these terms. Seller's acceptance of Buyer's offer to purchase, or Buyer's acceptance hereof, is limited and restricted to these terms. Seller objects to and refuses to be bound by any terms additional to or different from those contained herein.

2. Prices are subject to change without notice, and all orders are to be invoiced at Seller's prices prevailing at time of shipment.

3. Any taxes which Seller may be required to pay or collect under existing or future law upon or with respect to the sale, purchase, delivery, transportation, storage, processing, use, or consumption of any of the products or services covered hereby, including all taxes upon or measured by receipts from sales or services, shall be for the account of Buyer, who shall promptly pay the amount thereof to Seller upon demand.

4. All accounts are payable in United States funds, free of exchange, collection or other charges. If Buyer fails to fulfill the terms of payment or if Seller shall have any doubt at any time as to Buyer's financial responsibility, Seller may suspend production and decline to make shipment or delivery except upon receipt of cash or security satisfactory to Seller.

5. Unless otherwise specifically provided herein, delivery will be made f.o.b. point of shipment, all risk of loss shall pass to Buyer upon delivery to carrier, and Buyer shall be responsible for obtaining insurance if desired. The method and agency of transportation and the routing, unless specified on the face hereof, will be selected by Seller, and Seller reserves the right to ship freight collect. Shipping dates are approximate and are based on prompt receipt of all necessary information.

6. Seller shall not be liable for any delay in performance due to fire, explosion, casualty, strike or other labor difficulties, shortage of material, utility, facility or labor, delay in transportation, breakdown or accident, compliance with or other action taken to carry out the intent or purpose of any law or regulation, or any cause whether similar or dissimilar beyond Seller's reasonable control, and Seller shall have such additional time for performance as may reasonably necessary under the circumstances and the right to apportion its production among its customers in any manner it sees fit.

7. Any claims for shortages, damaged products, or non-conformance of products with the order must be made in writing within ten (10) days after receipt of shipment, and Seller must be afforded an opportunity to investigate.

8. Cancellation or alteration of an order or

return of any product by Buyer may not be made without advance written consent by Seller and, at Seller's option, shall be subject to a cancellation, alteration or return charge acceptable to Seller.

9. Seller warrants that its products are free from defects in material and workmanship.

10. In the event of breach of any warranty hereunder, Seller's sole and exclusive liability shall be at its option either to repair or replace, f.o.b. point of shipment, any defective product, or to accept return, transportation prepaid, of such product and refund the purchase price; in either case provided that such product within 12 months from date of shipment to Buyer is found by Seller to have been defective at the time of such shipment, that the product has been installed and operated in accordance with generally approved practice and in accordance with Seller's instructions, that no repairs, alterations or replacements have been made by others without Seller's written approval, and that Buyer notifies Seller in writing within 15 days after the defect becomes apparent and promptly furnishes full particulars in connection therewith; and provided further that in no event shall the aggregate liability of Seller in connection with breach of any warranty or warranties exceed the purchase price paid for the products purchased hereunder. Seller, may, at its option, require the return of any product, transportation and duties prepaid, to establish any claim of defect made by Buyer. EXCEPT AS EXPRESSLY STATED IN THIS INSTRUMENT, SELLER MAKES NO WARRANTIES, EXPRESS OR IMPLIED, AND DOES NOT WARRANT THAT THE PRODUCTS SOLD HEREUNDER ARE MERCHANTABILITY OR FIT FOR ANY PARTICULAR PURPOSE.

11. Seller will defend at its own expense any suit or legal proceeding instituted against Buyer, and will pay any damages and costs awarded therein against Buyer, insofar as the same are based on a claim that any product furnished hereunder, except as excluded below, in itself constitutes an infringement of any United States patent, provided Buyer gives Seller prompt written notice of such infringement claim and of the institution of such suit or proceeding and also gives Seller all necessary authority, information and reasonable assistance to enable Seller, at Seller's option, to settle or defend the same. In case any said product is held in such suit to constitute an infringement and its use is enjoined, Seller at its own expense will either procure for Buyer the right to continue using said product, or modify same so that it becomes non-infringing, or replace it with a non-infringing product, or remove the product and refund the purchase price paid therefor by Buyer. The foregoing provisions state Seller's entire obligation and liability for patent infringement; and it is understood and agreed that there shall be excluded from the operation of said provisions any and all products

furnished in accordance with particular designs, specifications or instructions furnished or expressly or impliedly prescribed by Buyer and not customarily followed by Seller in the course of its general business, and Buyer will indemnify and hold harmless Seller from and against all loss, cost, expense, damage and liability of any nature or kind for or on account of any patented or unpatented invention or trade secret which in compliance with any such designs, specifications or instructions is embodied in any product furnished hereunder.

12. Seller shall not, except as set forth above, be otherwise liable to Buyer or to any person who shall purchase from Buyer, or use, any products supplied hereunder for damages of any kind, including, but not limited to, direct, indirect, special or consequential damages or loss of production or loss of profits resulting from any cause whatsoever, including, but not limited to, any delay, act, error or omission of Seller.

13. Technical information, recommendations and advice as to properties and usages of materials, design, installation and use of products, engineering and other matters are provided as an accommodation and are intended only as suggestions. Although they are believed to be accurate, based on Seller's best knowledge and experience, Seller assumes no obligation or liability for any results obtained in their use or application, and they are not to be construed as establishing any warranty, express or implied.

14. This agreement shall inure to the benefit of and be binding upon the successors and assigns of the parties hereto.



P.O. Box 32160  
Louisville, KY 40232-2160

2612 Howard Street  
Louisville, KY 40211

Phone: 502-774-6011  
Fax: 502-774-6300

Website: [www.SyprisTechnologies.com](http://www.SyprisTechnologies.com) • E-mail: [tubeturns@SyprisTechnologies.com](mailto:tubeturns@SyprisTechnologies.com)

The information contained herein is based on data and information developed in the Laboratories of Sypris Technologies ("Seller"), but is presented without guarantee or warranty, and the seller disclaims any liability incurred from the use thereof. Nothing contained herein is to be construed as a recommendation for any use, including without limitation, any use in a commercial process not controlled by seller, nor for a use which is in violation of any existing patent, foreign or domestic or of applicable laws and regulations.