

YOKE STYLE CLOSURES

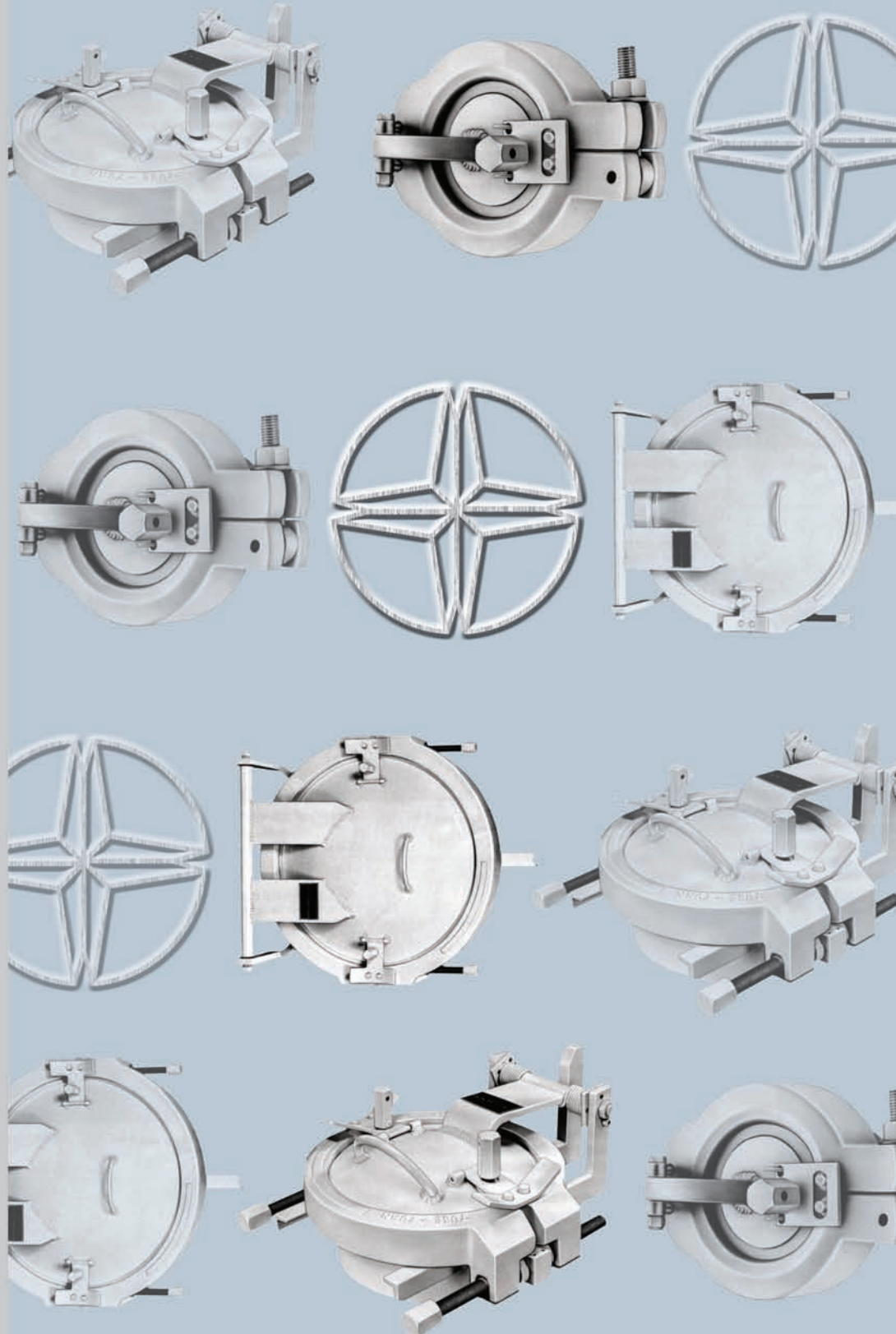

DOUBLE BOLT YOKE CLOSURES

The Tube Turns Double Bolt Yoke Style Closure is compact in size and functional in design. A typical unit consists of a forged hub, a hinged blanking head, split-yoke clamps, operating bolts, and a self-energizing O-ring gasket. Materials of construction are in accord with ASME specifications and manufacture complies with applicable rules of the ASME Code for Pressure Piping and with the ASME Boiler and Pressure Vessel Code.

Size and Rating

Double-bolt yoke style hinged closures are available in pressures ranging from 285 PSI to 6170 PSI and can be used in a horizontal or vertical application. They are furnished in Carbon Steel, Stainless Steel, Low Temperature materials and other alloys depending upon availability of raw material. Adding further to the completeness of Tube Turns Hinged Closures is the availability of standard designs in sizes, 2" to 42" in carbon steel, stainless steel, and other alloys. Sizes up to 72" O.D. have been produced on special orders.

Materials of Construction

Standard construction material is Carbon Steel made to ASME specifications i.e. SA105 or SA106 grade B/C for the hub, SA516 grade 70 or SA105 for the head, SA105, SA106 Grade B/C or SA352 LCB for

the yoke, SA193 Grade B7 for yoke bolts and SA36 for structural components. Buna-N O-ring material is furnished unless another material is specified. Yoke bolts are fluorocarbon coated to lubricate the threads and prevent rust and corrosion of these working parts.

Tube Turns Hinged Closures can be equipped with sight glasses, drains, gauges, sampling ports, etc. The size and number of such openings is dependent upon the thickness of the closure head and whether threaded or socket-weld openings are utilized. Since the welding of sight glass frames, nipples, couplings and other appurtenances to the closure head or hub may result in distortion unless precautionary measures are taken; these attachments should be added at time of manufacture.

Faster, Easier Operation

Operation is smooth and direct, and even the largest unit can be opened or closed in a matter of minutes. Turning of the actuating bolts - accomplished by one man using only standard hand tools - spreads the yoke halves until they are fully separated, allowing the head to be swung open on its hinge. There is no need to tug or hammer at bulky flanges or heavy metal doors...or to struggle with bulky lugs and threads. Contact surfaces of the clamping yokes,

head and hub are tapered and when the head is closed and the yoke bolts are tightened, the head and hub are wedged together, compressing the O-ring and effecting a leakproof seal.

Maintenance Minimized

The standard gasket for Tube Turns Hinged Closures is an oil-resistant O-ring that is stationary when the head is being opened or closed. There is no rubbing or chafing that could cause undue wear and shorten seal life. The yokes separate evenly via the use of two yoke bolts preventing wear on the yoke contact surfaces. The yoke bolts are coated with fluorocarbon to lubricate the threads and to prevent rust and corrosion of these working parts.

Many of our closures manufactured as far back as the 1960's are still in operation only requiring periodic replacement of spare parts. Tube Turns keeps a serialized record of each closure to allow easy identification of replacement parts.

The Tube Turns Hinged Closure is remarkably easy to install, too...a single circumferential butt weld joining the closure hub to the pipe end or vessel nozzle does the job. Complete installation, operating and maintenance instructions are furnished with each Tube Turns Hinged Closure and additional copies are available upon request.



Typical of Tube Turns Yoke Type Hinged Closures being used with scraper traps.

DOUBLE BOLT YOKE CLOSURES

Yoke Style Closures Allowable Working Pressures (Ratings)

In general, the pressure classes established for Tube Turns Hinged Closures refer to ASME/ANSI B16.5 ratings used in normal piping terminology. This is done as a matter of convenience to give the engineer a clear understanding of service limitations and the exact Hinged Closure design required for a particular application.

Maximum allowable working pressures for carbon steel Tube Turns Yoke Type Hinged Closures are:

Closure Pressure Class	ASME/ANSI Service to 450 °F
150	285
300	740
600	1480
900	2220
1500	3705
2500	6170

O-Ring Materials

The maximum temperatures are based on 100% compression set in 1000 hours. The O-rings may be used at higher temperatures but with an undetermined decreased life.

“Buna-N” - General service. Resistant to petroleum-base hydraulic and lubricating oils; animal and vegetable oils; gases such as butane, propane, acetylene and natural gas; aromatic and nonaromatic fuels such as gasoline, kerosene, diesel fuel and fuel oils; anhydrous ammonia, and water. Temperature limits: -30F to 250F; special compounds suitable for -65F.

“Viton” - Generally used for high-temperature services. Resistant to synthetic lubricants, petroleum-base products, some chlorinated solvents, benzene, toluene, and many acids and alkalis. Temperature limits: -20F to 400F.

“Ethylene Propylene”

Superior resistance to phosphate-ester type fluids, Skydrol, Pydrol, Cellulubes and glycol type coolants. Excellent resistance to mild acids and alkalis. Can be used in steam service. Replacing butyl rubber in most applications. Temperature limits: -70F to 300F.

“Silicone Rubber” - Good resistance to high and low temperature dry gases, air, oxygen and ozone. May be satisfactory in high-aniline oils, but not recommended for use with most petroleum base products. Temperature limits: -65F to 450F.

Note: Determination of compatibility of O-ring material with medium is the responsibility of the purchaser.

ASME Code-Stamped Closures

Code stamping of Tube Turns Hinged Closures is available on request at a nominal extra cost. This includes (1) the furnishing of a Partial Data Sheet verifying shop inspection of the unit by a commissioned inspector of the National Board of Boiler and Pressure Vessel Inspectors, and (2) the affixing of the ASME stamp.

Manufacturer’s Statement of Code Compliance

In the event that shop inspection and stamping in accordance with Section VIII of the ASME Boiler and Pressure Vessel Code is not required, Tube Turns can furnish a Manufacturer’s Statement of Code Compliance. This document affirms that the Hinged Closure is manufactured in accordance with the applicable requirements of the Code.

Ordering Data

When inquiring and/or purchasing Tube Turns Hinged Closures, please specify the following:

1. Quantity required
2. Size required
3. Material required
4. Design conditions - both pressure and temperature
5. Minimum design metal temperature - the lowest temperature to which closure will be subjected.
6. Application - horizontal (opens like a car door) or vertical (opens like a car hood)
7. Bore (wall thickness) required
8. ASME code stamp and partial data reports required
9. O-ring materials required
10. Corrosion allowance if applicable.

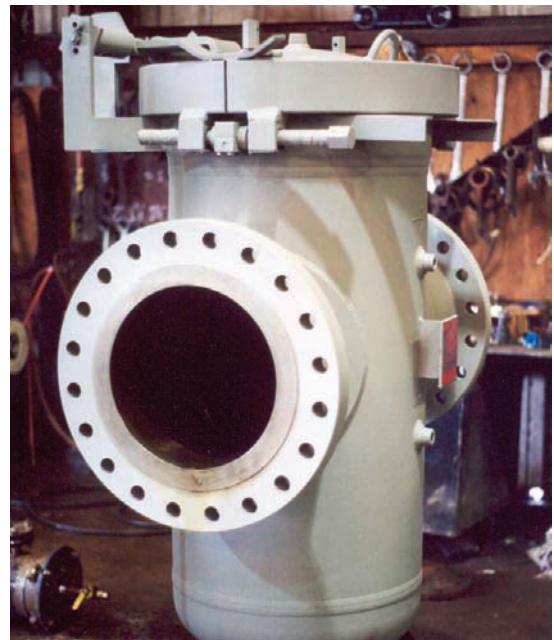

DOUBLE BOLT YOKE CLOSURES

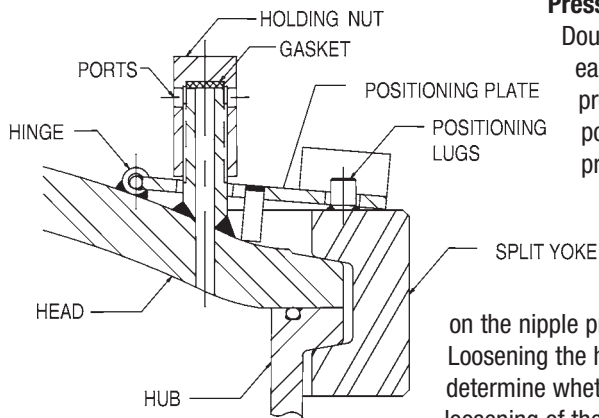

Pressure Warning Device With Yoke Positioning Plate

Double Bolt Yoke Closures are equipped with 2 pressure warning devices on each closure. The Pressure Warning Device with yoke positioning plate provides visual and mechanical assurance that the yokes are in the correct position over the head for commencement of operations. Additionally, the pressure warning device serves the purpose of alerting the operator to any residual pressure in the vessel should the operator inadvertently attempt to open the closure before all pressure has been relieved. A pressure warning device is located at each of the yoke splits with one of the positioning lugs attached to each yoke half. Tightening the holding nut on the nipple provides a seal and locks the hinged positioning plate on the positioning lugs. Loosening the holding nut breaks the seal and provides a means by which the operator can determine whether the vessel has been completely relieved of internal pressure. Continued loosening of the holding nut will allow the disengagement of the positioning plate from the positioning lugs, permitting the yoke halves to be spread and the closure to be opened.

Safety Locking Device

An additional feature that can be added to the Yoke Style Closure is the Safety Locking Device. This device is intended to prevent opening of the closure under pressure. It consists of a cylinder/piston connected to the interior of the closure and a latch plate. Whenever there is pressure inside the closure the piston is extended and engages the latch plate. This prevents opening of the closure under pressure. When the pressure has been reduced, the piston retracts, allowing the closure to be opened. This is a closed system and does not release its contents to the atmosphere.

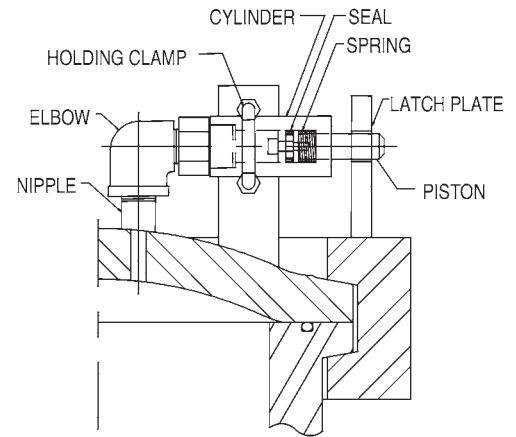

Operating Aids

Tube Turns furnishes a variety of operating aids to speed and simplify the opening and closing of Yoke Type Closures. These range from simple, break-over wrenches, to chain-and-sprocket drives, to fully automated models. Attached break-over wrenches are available. These are attached directly to the bolts and eliminate the need for a wrench. Examples are on Page 21. The Chain and Sprocket Drive option is by far the most economical opening assist device we offer. This is a manually operated aid which assists in the opening and closing of the yoke bolts. These units not only make the process faster, they also prevent the uneven movement of the yokes which may cause binding. On larger closures, ratio reduction is available to further ease the force required to turn the unit. Hand wheels can also be furnished which provides faster operation and eliminates the need for additional tools. The basic pattern of the Tube Turns' Chain and Sprocket Drives follows the basic principal of the familiar bicycle chain and sprocket arrangement. Same size sprockets are attached to longer than standard yoke bolts. Positioned around the sprockets is a linked belt or chain. For safety precautions, a chain and sprocket guard is furnished. A lever or crank is fitted to one of the sprockets which, when turned, rotates both yoke bolts simultaneously. This device can be modified by changing the ratio of the sprockets to increase the speed and ease of opening the yoke bolts. Tube Turns can further automate their yoke style closures by designing opening and closing devices which are either electrically, pneumatically or hydraulically operated. These devices cannot only be designed to open and close the yoke bolts, but they can also raise and lower the head for vertical applications.

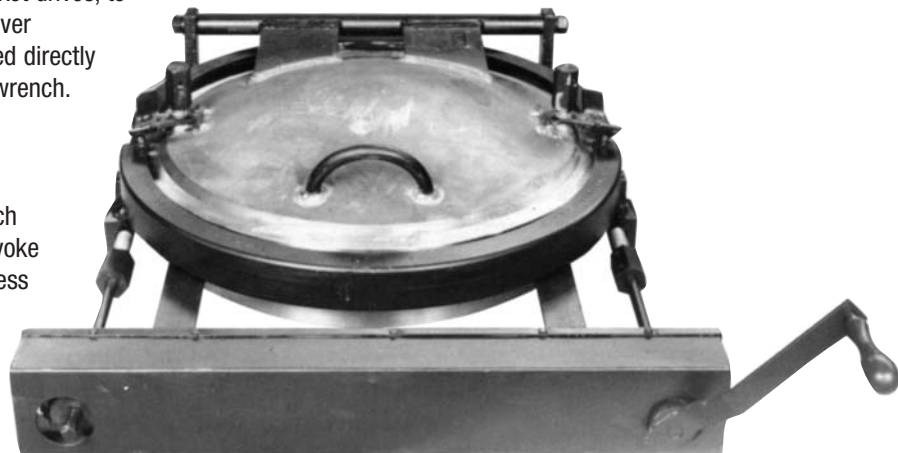

Double Bolt Yoke Closure with Chain & Sprocket Drive.

DOUBLE BOLT YOKE CLOSURES

Tube Turns Automated Closures have flexibility of design and can be developed and manufactured to meet your needs. Our Automated Closures are located in industries throughout the world. Applications for Tube Turns Automated Closures include Pipeline Launchers and Receivers and operations with batch processes such as pulp and paper mills, food process, chemical plants and petrochemical plants.

In addition to this flexibility, our Automated Yoke Style Closures have other advantages.

1. SAFETY- Automation provides a tight seal which prevents leakage and exposure of the operators to fumes and the medium which is potentially hazardous to their health. To prevent inadvertent opening of these closures, they are normally furnished with the following safety systems:

- a. Electrically Operated Closures are equipped with a pressure switch and an electrical relay.
- b. Pneumatically Operated Closures are equipped with a pressure switch and a solenoid valve.
- c. Hydraulically Operated Closures are equipped with a pressure switch and an electrical relay.

2. IMPROVED EMPLOYEE MORALE - With the environmental concerns in industry today, Tube Turns' Automated Closure enables the operators to be stationed away from the reactor thus eliminating their exposure to the fumes and medium involved in the opening and closing operation. As a result, the operator's health concerns are reduced significantly. The very fact that in most instances the closure head is hinged means elimination of pinched fingers and toes or badly skinned knuckles that too often occur with the use of flanges.

3. ECONOMIC CONSIDERATIONS

A. It is fast! Depending upon size, the opening and closing cycle can take less than one minute.

B. One man can open it. He does so by merely pushing a button. As a result of these savings in operating cost, an early payback in your initial investment can be realized.

4. MAINTENANCE - Since operation is simple, direct and positive, Tube Turns' Automated Closures require little or no maintenance other than replacement of the O-ring and periodic inspection of yoke bolts and nuts for wear. The human element is virtually eliminated in that the automation mechanism of the closure performs all the work.

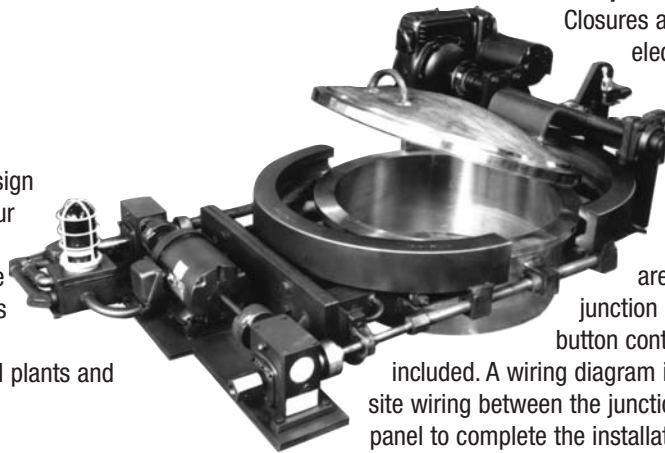

Electric Operated Automated

Closures are supplied with electric motors and appropriate gear boxes to drive the yoke bolts and to open and close the head. Electric circuits are wired to a central junction box and a push button control panel is included. A wiring diagram is provided for on-site wiring between the junction box and control panel to complete the installation.

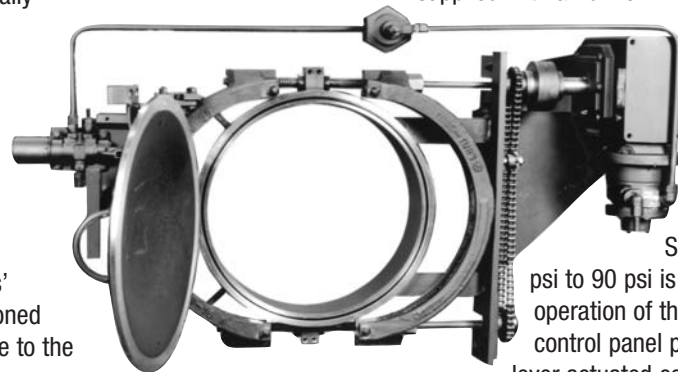

Pneumatic Operated Automated Closures are

supplied with air driven motors, a gear box to drive the yoke bolts through a joint chain drive and a gear box to open and close the head. Shop air from 60 psi to 90 psi is used for operation of the unit through a control panel provided with lever actuated control valves.

Hydraulic Operated Automated Closures are similar to those described above except that hydraulic motors are used for the driving force. A hydraulic pump system with electric controls can be provided with the units or by the end user.

DOUBLE BOLT HORIZONTAL DIMENSIONS

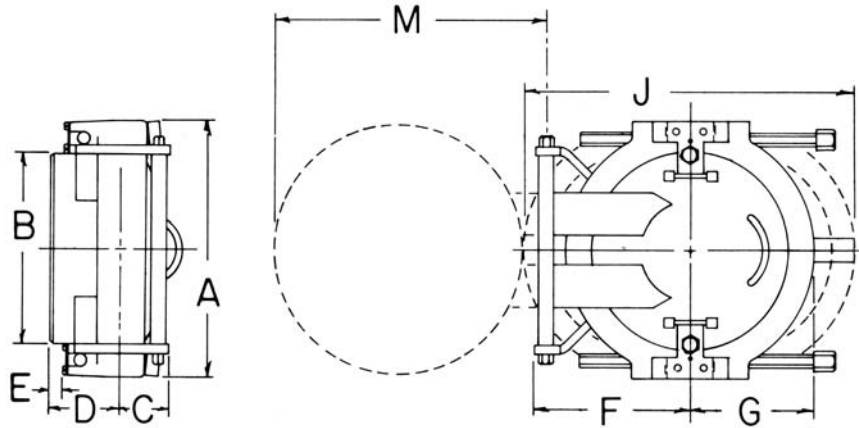
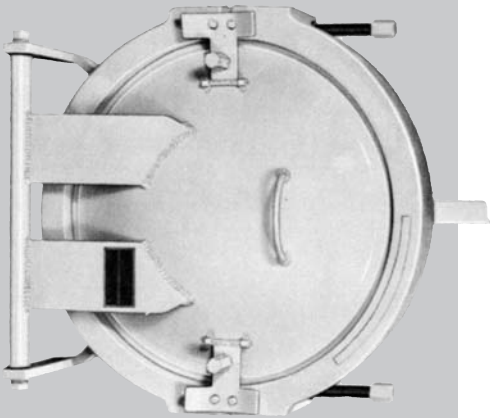

U.S. PAT. NO. 3,077,360

	Nominal Size	Over-all A	OD at Welding Bevel B	Back to Face Max. C	Hub Length D	Clear Hub Length E	Center to Hinge End F	Center to Free End G	Yoke Clearance J	Opening Clearance M	Approx. Weight Lbs
Class 150-H Double Bolt Horizontal	8	12 11/16	8 5/8	2 9/16	4	5/8	7 1/8	5 1/2	15 1/8	11 3/16	60
	10	14 7/8	10 3/4	2 11/16	4 1/4	7/8	8 1/2	6 3/4	18 1/8	13 1/8	80
	12	16 7/8	12 3/4	2 5/8	4 1/4	13/16	8 9/16	7 3/4	20 3/8	14 3/4	110
	14	18 1/8	14	2 11/16	4 1/4	3/4	9 5/16	8 7/16	22	16 1/8	130
	16	20 7/8	16	2 11/16	4 5/8	11/16	10 3/8	9 1/2	26 7/16	18 1/4	160
	18	22 7/8	18	2 11/16	4 5/8	11/16	11 1/2	10 1/2	28 7/16	20 1/4	190
	20	24 7/8	20	3 1/8	4 5/8	5/8	12 13/16	11 1/2	30 1/2	22 9/16	220
	22	26 7/8	22	3 1/4	4 5/8	5/8	14	12 9/16	32 1/8	24 11/16	260
	24	28 7/8	24	3 1/4	4 5/8	5/8	15	13 5/8	34 5/8	26 11/16	310
	26	30 7/8	26	3 5/16	5	1/2	16 1/16	14 11/16	37 3/8	28 13/16	370
	28	32 7/8	28	3 1/2	5	7/16	17 9/16	15 3/4	39 7/8	31 5/16	440
	30	34 7/8	30	3 5/8	5 1/2	13/16	19	16 15/16	43	33 3/8	530
	32	37 5/8	32	4	5 1/2	1/2	20 3/8	18	45 3/8	35 3/4	600
	34	39 5/8	34	4	5 1/2	1/2	21 3/8	19	47 5/8	37 3/4	680
	36	41 5/8	36	4 1/8	6	13/16	22 3/8	20 1/16	50	39 3/4	780
	38	44 1/8	38	4 1/8	6	3/4	23 3/8	21 1/8	52 3/8	41 3/4	880
40	46 1/8	40	4 1/4	6	5/8	24 7/16	22 5/16	55 5/8	43 7/8	990	
42	48 1/8	42	4 5/8	6 1/8	5/8	25 7/16	23 5/16	57 7/8	45 7/8	1150	
Class 300-H Double Bolt Horizontal	8	12 11/16	8 5/8	2 9/16	4	5/8	7 1/8	5 1/2	15 1/8	11 3/16	60
	10	14 13/16	10 3/4	2 11/16	4 1/4	7/8	8 1/2	6 3/4	18 1/8	13 1/8	80
	12	16 13/16	12 3/4	2 3/4	4 1/4	15/16	8 1/2	7 3/4	21	14 11/16	110
	14	18 3/16	14	2 7/8	4 1/4	15/16	9 5/16	8 7/16	22 13/16	16 1/8	140
	16	20 15/16	16	3 5/16	5	1	12 3/8	9 1/2	26 1/2	19 15/16	170
	18	23 1/8	18	3 11/16	5 1/4	7/8	12 5/8	11 3/16	29 13/16	21 3/4	220
	20	25 1/4	20	4 1/8	5 5/8	11/16	13 7/8	12 5/16	33 1/8	24	300
	22	27 3/4	22	4 1/4	6 1/4	15/16	16 3/16	13 1/8	36 3/16	27 1/16	360
	24	30 9/16	24	4 5/8	6 1/2	1 1/8	16	14 11/16	38 7/16	28 1/8	460
	26	32 1/2	26	4 13/16	6 3/4	1 1/4	19 1/2	15 7/16	42	32 1/8	570
	28	34 3/4	28	5	7 1/2	1 5/16	20 1/2	16 1/2	44 9/16	34 1/8	700
	30	36 7/8	30	5 1/8	7 3/4	1 7/16	21 11/16	17 11/16	47 11/16	36 7/16	840
	32	38 7/8	32	5 3/16	7 3/4	1 3/8	22 11/16	18 3/4	50 3/16	38 7/16	980
	34	42 1/4	34	5 7/16	8 1/4	1 3/8	21 7/8	20	53 7/16	38 3/4	1150
	36	44 1/4	36	5 7/16	8 1/2	1 9/16	23 3/8	21 1/16	56	40 3/4	1350
	38	46 3/8	38	5 5/8	8 3/4	1 11/16	24 5/8	22 1/4	59 1/16	43 1/8	1600
40	48 7/8	40	5 13/16	9 1/4	1 11/16	25 5/8	23 3/8	62 1/16	45 3/16	1850	
42	51	42	5 15/16	9 1/2	1 7/8	26 3/4	24 1/2	64 7/16	47 3/8	2100	

See notes on page 11.

DOUBLE BOLT HORIZONTAL DIMENSIONS

	Nominal Size	Over-all A	OD at Welding Bevel B	Back to Face Max. C	Hub Length D	Clear Hub Length E	Center to Hinge End F	Center to Free End G	Yoke Clearance J	Opening Clearance M	Approx. Weight Lbs
Class 600-H Double Bolt Horizontal	8	12 3/4	8 5/8	2 7/8	4 1/4	5/8	8 1/8	5 15/16	16 3/4	12 5/16	90
	10	14 7/8	10 3/4	3 1/8	4 7/16	5/8	9	7 3/16	20	14 5/16	150
	12	17 5/8	12 3/4	3 5/16	5 3/16	3/8	9 3/8	8 1/4	22 3/8	15 5/8	180
	14	19	14	3 15/16	5 1/4	5/16	9 15/16	9	24 7/8	16 7/8	220
	16	21 7/8	16	4 1/4	6 1/16	9/16	13 3/16	10 11/16	29 1/8	21 3/16	380
	18	24 7/8	18	4 9/16	6 1/4	1/2	14 1/4	12 1/4	33 3/4	23 11/16	480
	20	27 1/8	20	4 13/16	7	3/8	15 5/16	13 1/2	37	25 5/16	620
	22	29 1/8	22	5 1/2	8	1 3/16	16 3/16	14 1/2	39 3/4	27 3/16	750
	24	32 1/8	24	5 3/8	8 3/8	1 3/16	17 7/8	15 3/8	42 1/2	29 13/16	900
	26	34 3/8	26	5 11/16	8 9/16	1 1/4	18 1/2	16 11/16	46 1/4	31 5/8	1120
	28	36 1/16	28	5 13/16	8 3/4	1 5/16	19 3/4	17 7/8	49 1/2	33 13/16	1380
	30	38 9/16	30	6 3/16	9 1/2	1 3/8	20 11/16	19	52 1/4	35 3/4	1700
	32	40 13/16	32	6 1/4	9 1/2	1 3/8	21 7/8	20 1/4	55 1/8	38 1/16	2000
	34	43 13/16	34	6 1/4	10	1 3/16	22 15/16	21 1/2	58 1/8	40 1/4	2320
	36	45 13/16	36	6 11/16	10 1/4	1 3/16	24 11/16	22 1/2	60 5/8	42 3/8	2750
	38	48 7/16	38	6 11/16	10 3/4	1 5/16	25 7/8	23 5/8	63 1/4	44 9/16	3280
	40	50 7/16	40	6 13/16	10 3/4	1 5/16	26 3/4	24 3/4	65 3/4	46 7/16	3450
	42	53 1/16	42	7 3/16	11 7/8	1 7/16	27 13/16	26	69 1/2	48 5/8	4000
Class 900-H Double Bolt Horizontal	8	12 13/16	8 5/8	3 7/16	4 9/16	9/16	9	6 1/4	18 7/16	13 5/16	140
	10	15 15/16	10 3/4	3 11/16	5 7/8	1 1/16	11 1/16	7 3/4	22 1/4	16 3/8	230
	12	18 15/16	12 3/4	4 9/16	6 3/8	11/16	12 1/2	9 3/16	25 7/8	19	340
	14	20 1/2	14	4 11/16	6 5/8	13/16	13 1/8	9 15/16	28 1/16	20 1/4	430
	16	23	16	5 1/8	7 1/2	11/16	15 7/16	11 1/4	31 1/4	23 3/16	600
	18	25 1/16	18	5 3/8	7 13/16	1	17	12 1/4	35	25 13/16	900
	20	28 3/8	20	5 15/16	8 1/2	1 1/8	17 7/8	13 1/2	37 5/8	27 3/4	1200
	22	30 1/2	22	6 1/4	8 3/4	1 3/16	19 1/8	14 13/16	40 7/8	30 1/8	1580
	24	33 1/8	24	6 5/8	9 1/2	1 1/4	20 7/16	16 1/8	44 1/2	32 9/16	2000
	26	35 1/8	26	7	9 3/4	1 9/16	21 3/4	17 1/2	47 3/4	35	2100
	28	38 1/4	28	7 3/16	10 1/2	1 3/16	24	18 3/4	51	37 13/16	2550
	30	40 3/8	30	8 5/16	10 13/16	1 1/8	25 3/16	20 1/16	54	40 1/8	3100
	32	43	32	8 5/8	11 1/2	1 7/16	26 3/4	21 5/16	57 1/2	42 3/4	3700
	34	45 3/4	34	8 1/16	12 1/2	1 5/8	27 3/4	22 5/8	61	44 7/8	4200
	36	48 5/8	36	10	13 5/16	1 13/16	30	23 15/16	64 1/2	47 3/4	5200
	38	50 5/8	38	9 11/16	13 3/8	1 11/16	31 5/16	25 3/16	67 5/8	50 1/8	5700
	40	53 3/4	40	9 3/4	13 3/4	1 9/16	32 5/8	26 1/2	70 3/4	52 9/16	6600
	42	55 7/8	42	10 9/16	14 1/8	1 3/4	34	27 13/16	74 1/8	55 1/16	7600
Class 1500-H Double Bolt Horizontal	6	11 13/16	6 5/8	4 3/16	6	7/8	9 1/16	5 1/2	16 3/4	12 1/2	125
	8	14 1/16	8 5/8	4 5/16	6 1/4	7/8	10 5/8	6 3/4	20 1/4	15 1/4	230
	10	17 1/16	10 3/4	4 7/8	7 1/2	1 3/8	11 7/8	8 3/8	24 1/2	17 1/2	400
	12	20 1/8	12 3/4	5 3/16	8 1/2	2 1/16	13 3/4	10	29 1/16	20 11/16	650
	14	21 5/8	14	6	8 3/4	1 9/16	15 5/16	10 3/4	30 3/4	22 5/16	800
	16	24 7/8	16	5 1/16	10	2 5/16	17	12 3/8	35	25 3/8	1200
	18	27 9/16	18	7 1/16	10 1/2	2 1/8	19	13 3/4	40	28 3/8	1600
	20	30 3/4	20	7 1/2	10 3/4	1 9/16	19 5/8	15 5/16	43 1/2	30 3/8	2200
	22	33	22	8 1/16	12	2	20	16 1/2	46	33 1/8	2700
	24	36 7/8	24	8 7/16	12 3/4	2 1/4	23 7/8	18 3/8	51	37 1/8	3550
	26	39 11/16	26	9	13 3/4	2 9/16	24 1/2	19 13/16	54 7/8	38 13/16	4500
	28	41 5/16	28	10 1/8	14 3/4	3	27	20 11/16	58 7/8	41 1/4	5200
	30	44 5/8	30	10 1/4	15 3/4	3 3/8	28 1/2	22 5/16	62 1/2	44 3/16	6200

All dimensions are in inches. When ordering, please specify type, nominal size, bore, material and service conditions. NOTE: Type H Double Bolt Horizontal model closure is normally installed with hinge at the left when viewed facing the closure. If hinge location is desired in other than left position, this information should be made available at time of order. Otherwise opening, closing and maintaining correct yoke gap are problems that can result. Tube Turns Hinged Closures are regularly furnished in carbon steel; however, closures are also available in high yield strength steels. Closures are also available in other metals and alloys and in other sizes and pressure classes on special order. Chain-and-Sprocket Drives are available at extra cost (see page 8). Attached Break-Over Wrenches are available at extra cost (see page 21). For Pressure-Temperature Ratings, see page 7.

DOUBLE-BOLT HORIZONTAL PARTS

Class H Double-Bolt Horizontal Parts List

1. Hub	9. Nut (RH)	17. Hub Hinge Arm (Lower)	25. Support Arm
2. Head	10. Nut (LH)	18. Hinge Tube	26. O-Ring
3. Yoke	11. Yoke Bolt	19. Hinge Bearing	27. Pressure Warning Device and Positioning Plate
4. Bolt Holder (W)	12. Wrench Lug	20. Hinge Rod	28. Positioning Lugs
5. Bolt Holder (L)	13. Wrench Lug Pin	21. Hinge Rod Nut	
6. Cap Screws	14. Cover Plate	22. Lockwasher	
7. Yoke Bolt Bushing	15. Cap Screws	23. Head Hinge Arm	
8. Collar	16. Hub Hinge Arm (Upper)	24. Head Handle	

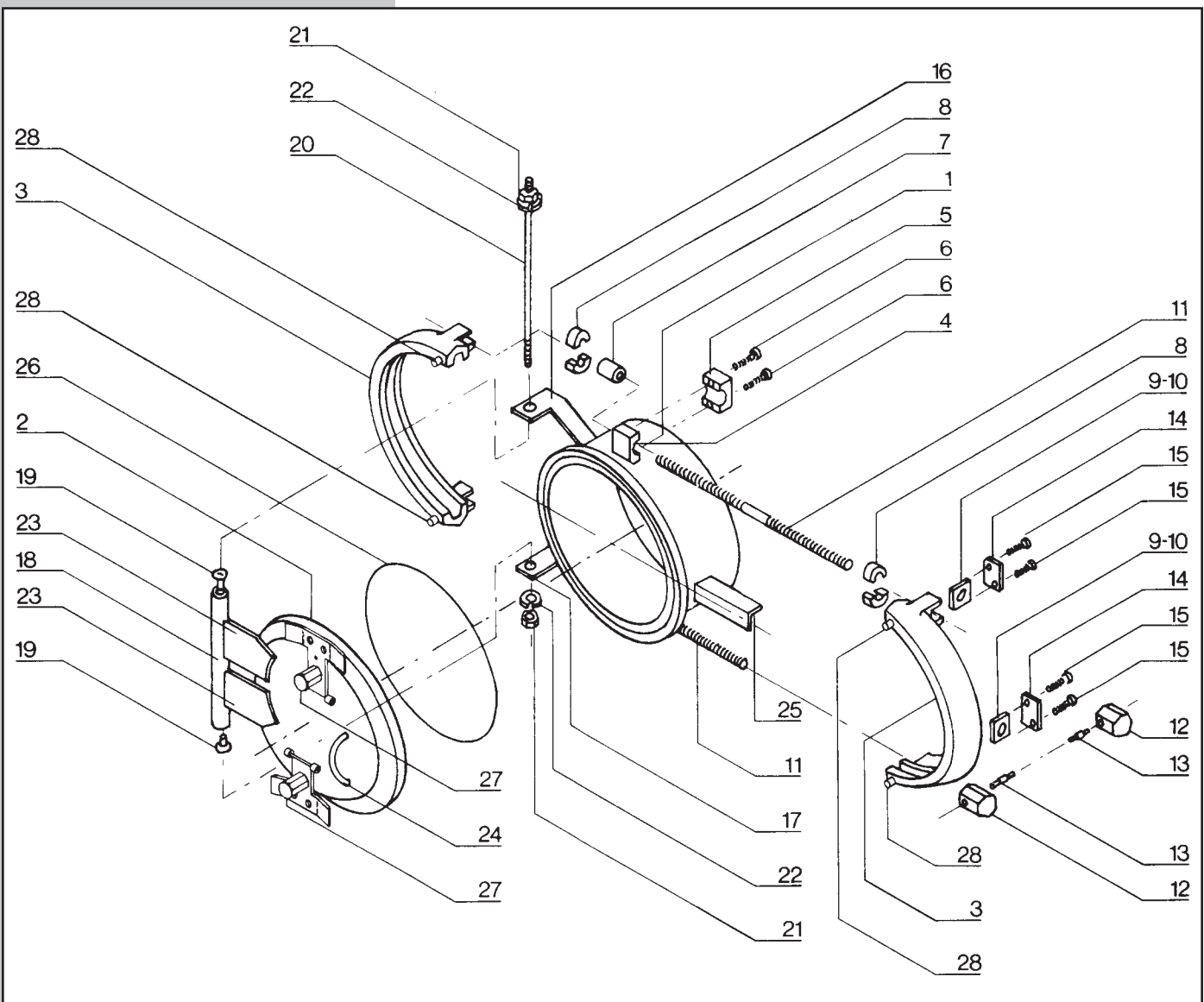

Spare Parts—It is suggested that the following spare parts be stocked for each closure:

Four O-Rings Part No. 26

Two Yoke Bolt Units consisting of:

Part Nos 7,8,9,10,11,12&13

When ordering spare parts, give amount, description, part number and size, pressure class and serial number of closure (located on front of yoke or ASME nameplate).

Example: (1) O-ring - Part Number 26 - 8" CL 600 - S/N 13845

DOUBLE BOLT VERTICAL DIMENSIONS

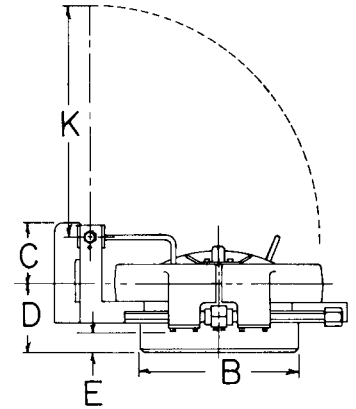
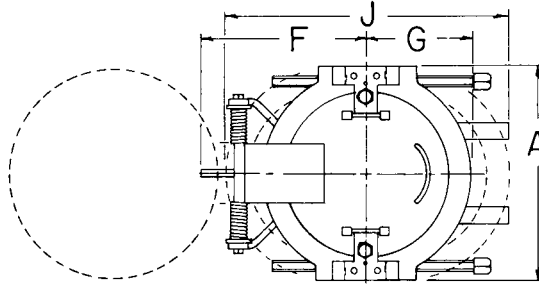
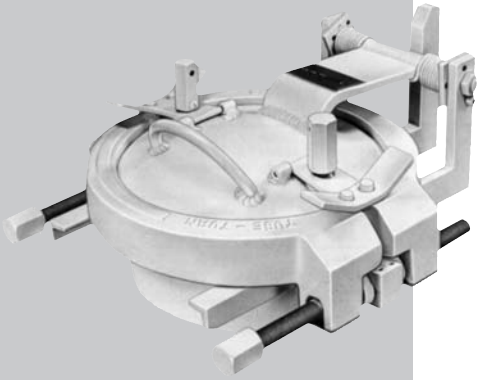

U.S. PAT. NO. 3,077,360

	Nominal Size	Over-all A	OD at Welding Bevel B	Back to Face Max. C	Hub Length D	Clear Hub Length E	Center to Hinge End F	Center to Free End G	Yoke Clearance J	Opening Clearance K	Approx. Weight Lbs
Class 150-V Double Bolt Vertical	8	12 11/16	8 5/8	4 3/16	4	5/8	9 9/16	5 1/2	15 1/8	12 1/16	60
	10	14 7/8	10 3/4	4 9/16	4 1/4	7/8	11 1/4	6 3/4	18 1/8	14 15/16	80
	12	16 7/8	12 3/4	4 3/8	4 1/4	13/16	12 9/16	7 3/4	20 7/16	17 1/4	110
	14	18 1/8	14	4 5/16	4 1/4	3/4	13 1/2	8 7/16	22	18 13/16	130
	16	20 7/8	16	4 13/16	4 5/8	11/16	14 1/4	9 1/2	24 15/16	19 5/8	170
	18	22 7/8	18	5 1/16	4 5/8	11/16	15 5/8	10 1/2	27 3/16	22 1/4	200
	20	24 7/8	20	6	4 5/8	5/8	16 3/4	11 1/2	29 7/16	24 1/16	230
	22	26 7/8	22	6 1/4	4 5/8	5/8	18 7/16	12 9/16	32 1/4	26 15/16	270
	24	28 7/8	24	6	4 5/8	5/8	19 5/8	13 5/8	34 5/8	28 1/16	320
	26	30 7/8	26	5 9/16	5	1/2	21 1/4	14 11/16	37 1/2	31	380
	28	32 7/8	28	6 5/8	5	7/16	23 7/16	15 3/4	40	32 3/4	450
	30	34 7/8	30	7 1/2	5 1/2	13/16	25 1/8	16 15/16	43 1/8	35 3/8	540
	32	37 5/8	32	9 1/2	5 1/2	1/2	29 1/8	18	45 9/16	37 1/8	620
	34	39 5/8	34	9 1/2	5 1/2	1/2	29 13/16	19	47 13/16	39 3/8	700
36	41 5/8	36	9 3/8	6	13/16	28 1/2	20 1/16	50 1/4	39 5/8	810	
38	44 1/8	38	9 3/8	6	3/4	29 3/4	21 1/8	52 9/16	42 1/8	910	
40	46 1/8	40	9 1/4	6	5/8	31 1/4	22 5/16	55 13/16	44 9/16	1030	
42	48 1/8	42	9 5/8	6 1/8	5/8	32 1/2	23 5/16	58 3/16	46 3/16	1200	
Class 300-V Double Bolt Vertical	8	12 11/16	8 5/8	4 3/16	4	5/8	9 9/16	5 1/2	15 1/8	12 1/16	60
	10	14 13/16	10 3/4	4 9/16	4 1/4	7/8	11 1/4	6 3/4	18 1/8	14 15/16	80
	12	16 13/16	12 3/4	4 1/2	4 1/4	15/16	12 9/16	7 3/4	20 13/16	17 1/4	120
	14	18 3/16	14	4 1/2	4 1/4	15/16	13 9/16	8 7/16	22 13/16	18 15/16	150
	16	20 15/16	16	7 13/16	5	1	15 1/16	9 1/2	25 7/8	19 13/16	180
	18	23 1/8	18	8 13/16	5 1/4	7/8	17 7/8	11 3/16	30 7/16	23 1/2	240
	20	25 1/4	20	8 1/4	5 5/8	11/16	18 11/16	12 5/16	33 1/8	25	320
	22	27 3/4	22	8 1/16	6 1/4	15/16	20	13 1/8	35 7/8	27 3/8	390
	24	30 9/16	24	8 1/2	6 1/2	7/8	22 9/16	14 11/16	38 9/16	29 7/8	490
	26	32 1/2	26	9 3/16	6 3/4	1 1/4	24 3/16	15 7/16	42 3/16	32 1/8	610
28	34 3/4	28	10 1/8	7 1/2	1 5/16	25 9/16	16 1/2	44 3/8	34 3/8	740	
30	36 7/8	30	10 1/2	7 3/4	1 7/16	27	17 11/16	47 11/16	36 1/4	890	

All dimensions are in inches. When ordering, please specify type, nominal size, bore, material and service conditions. Tube Turns Hinged Closures are regularly furnished in carbon steel; however, closures are also available in high yield strength steels. Closures are also available in other metals and alloys and in other sizes and pressure classes on special order. Lifting Eyes are provided on Vertical types when specified. Vertical Hinged Closures are furnished with spring-loaded heads. Heads counter-balanced by weights can be provided for larger sizes. They can be provided by Tube Turns on special orders. Chain-and Sprocket Drives are available at extra cost (see page 8). Attached Break-Over Wrenches are available at extra cost (see page 21). For Pressure-Temperature Ratings, see page 7

DOUBLE BOLT VERTICAL DIMENSIONS

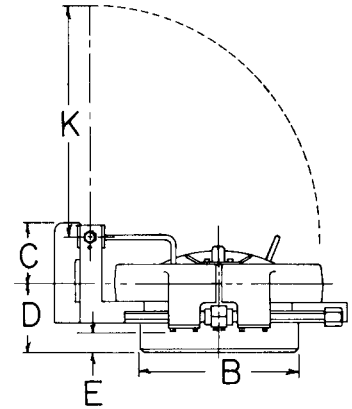
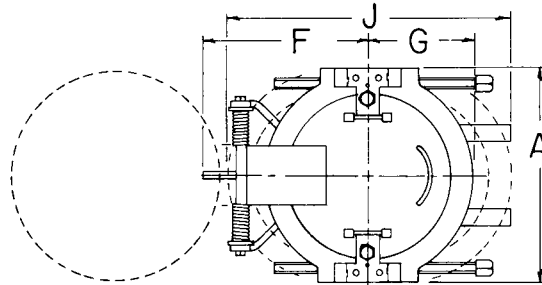
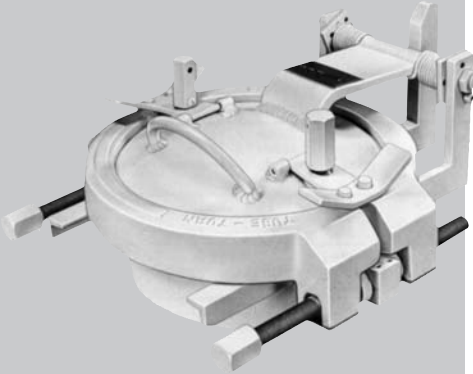

	Nominal Size	Over-all A	OD at Welding Bevel B	Back to Face Max. C	Hub Length D	Clear Hub Length E	Center to Hinge End F	Center to Free End G	Yoke Clearance J	Opening Clearance K	Approx. Weight Lbs
Class 600-V Double Bolt Vertical	8	12 3/4	8 5/8	4 1/2	4 1/4	5/8	10 3/16	5 15/16	16 7/8	12 15/16	90
	10	14 7/8	10 3/4	5 1/8	4 7/16	5/8	12 1/4	7 3/16	20 1/4	16	160
	12	17 5/8	12 3/4	5 13/16	5 3/16	3/8	13 3/16	8 1/4	22 5/8	16 1/16	190
	14	19	14	6 1/16	5 1/4	5/16	14 5/16	9	25 1/8	18 1/16	230
	16	21 7/8	16	7	6 1/16	9/16	17 1/16	10 11/16	29 3/8	21 3/4	360
	18	24 7/8	18	7 3/16	6 1/4	1/2	19 5/8	12 1/4	34	24 11/16	500
	20	27 1/8	20	11 11/16	7	3/8	21 7/8	13 1/2	37 1/4	28	840
	22	29 1/8	22	13 7/8	8	1 3/16	23 1/8	14 1/2	40	29 3/16	780
	24	32 1/8	24	12 1/4	8 3/8	1 3/16	23 3/4	15 3/8	42 3/4	31 1/4	930
	26	34 3/8	26	12 1/8	8 9/16	1 1/4	25 7/8	16 11/16	46 1/2	32 5/8	1160
28	36 1/16	28	12 3/4	8 3/4	1 5/16	27 3/4	17 7/8	49 7/8	35 9/16	1420	
30	38 9/16	30	13 3/8	9 1/2	1 3/8	29 3/4	19	52 3/4	35 3/4	1750	
Class 900-V Double Bolt Vertical	8	12 13/16	8 5/8	4 13/16	4 9/16	9/16	11 1/8	6 1/4	18 7/16	14 1/16	150
	10	15 15/16	10 3/4	7 1/16	5 7/8	1 1/16	12 15/16	7 3/4	22 1/4	16 5/16	230
	12	18 15/16	12 3/4	7 7/8	6 3/8	11/16	15 3/8	9 3/16	25 7/8	19 1/2	370
	14	20 1/2	14	8 1/8	6 5/8	13/16	16 1/8	9 15/16	28 1/16	20 1/8	470
	16	23	16	8 5/16	7 1/2	11/16	17 7/8	11 1/4	31 1/4	22 15/16	630
	18	25 1/16	18	9 1/2	7 13/16	1	20 1/2	12 1/4	35	25 13/16	930
	20	28 3/8	20	9 13/16	8 1/2	1 1/8	22 5/16	13 1/2	37 5/8	27 1/8	1230
	22	30 1/2	22	10 7/8	8 3/4	1 3/16	23 5/8	14 13/16	40 7/8	29 1/2	1620
24	33 1/8	24	13 1/2	9 1/2	1 1/4	25 1/4	16 1/8	44 1/2	32 3/4	2040	
Class 1500-V Double Bolt Vertical	10	17 1/8	10 3/4	8 11/16	7 1/2	1 3/8	14 3/8	8 3/8	24 1/2	17 1/2	400
	12	20 1/8	12 3/4	8 11/16	8 1/2	2 1/16	17	10	29 1/16	21 9/16	650
	14	21 5/8	14	8 3/16	8 3/4	1 5/8	19 3/16	10 3/4	30 3/4	23 3/8	800
	16	24 7/8	16	11 1/8	10	2 5/16	20 15/16	12 3/8	35	25 1/16	1200
	18	27 9/16	18	11 7/16	10 1/2	2 1/8	23	13 3/4	40	28 7/16	1600
20	30 3/4	20	13	10 3/4	1 5/8	25 1/8	15 5/16	43 1/2	30 7/8	2200	

All dimensions are in inches. When ordering, please specify type, nominal size, bore, material and service conditions. Tube Turns Hinged Closures are regularly furnished in carbon steel; however, closures are also available in high yield strength steels. Closures are also available in other metals and alloys and in other sizes and pressure classes on special order. Lifting Eyes are provided on Vertical types when specified. Vertical Hinged Closures are furnished with spring-loaded heads. Heads counter-balanced by weights can be provided for larger sizes. They can be provided by Tube Turns on special orders. Chain-and Sprocket Drives are available at extra cost (see page 8). Attached Break-Over Wrenches are available at extra cost (see page 21). For Pressure-Temperature Ratings, see page 7

DOUBLE-BOLT VERTICAL PARTS

Class V Double-Bolt Vertical Parts List

1. Hub	8. Collar	15. Cap Screws	22. Stop Arm	29. Adjusting Plate
2. Head	9. Nut (RH)	16. Hub Hinge Arm (RH)	23. Head Hinge Arm	30. Lock Screw
3. Yoke	10. Nut (LH)	17. Hub Hinge Arm (LH)	24. Head Handle	31. Pressure Warning Device And Positioning Plate
4. Bolt Holder (W)	11. Yoke Bolt	18. Hinge Tube	25. Support Arm	32. Positioning Lugs
5. Bolt Holder (L)	12. Wrench Lug	19. Hinge Bearing	26. O-Ring	
6. Cap Screws	13. Wrench Lug Pin	20. Hinge Rod	27. Spring (RH)	
7. Yoke Bolt Bushing	14. Cover Plate	21. Hinge Rod Nut	28. Spring (LH)	

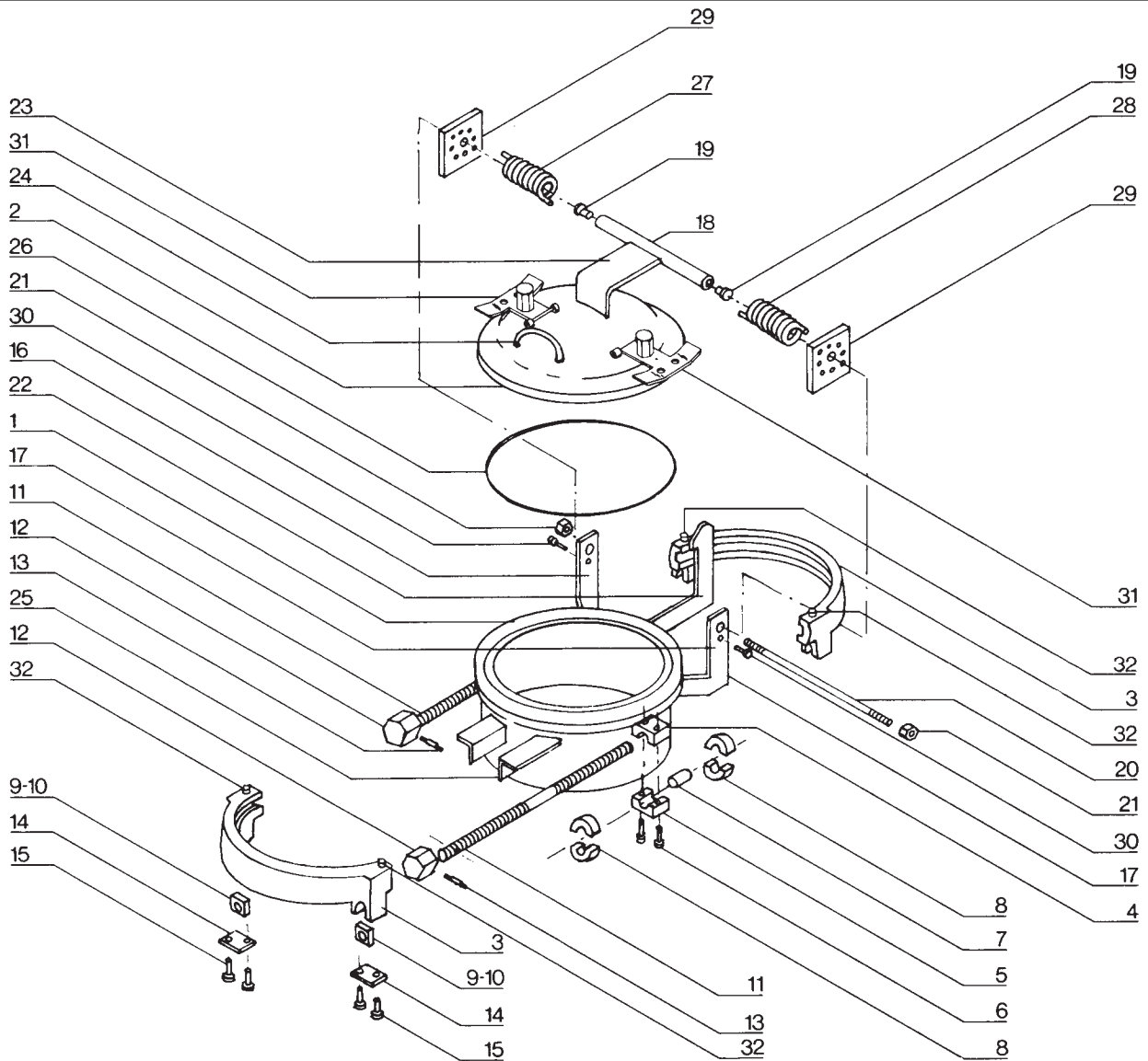

Spare Parts—It is suggested that the following spare parts be stocked for each closure:

Four O-Rings

..... Part No. 26

Two Yoke Bolt Units consisting of:

Part Nos 7,8,9,10,11,12&13

When ordering spare parts, give amount, description, part number and size, pressure class and serial number of closure (located on front of yoke or ASME name plate). Example: (1) O-ring - Part Number 26 - 8" CL 600 - S/N 13845

SINGLE BOLT CLOSURE

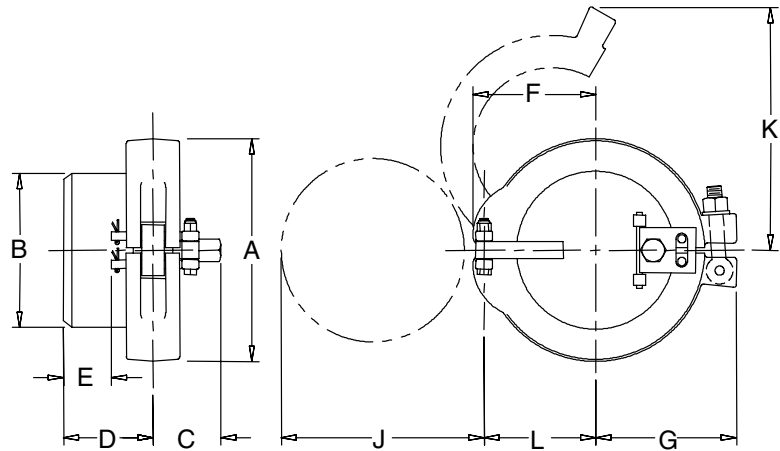
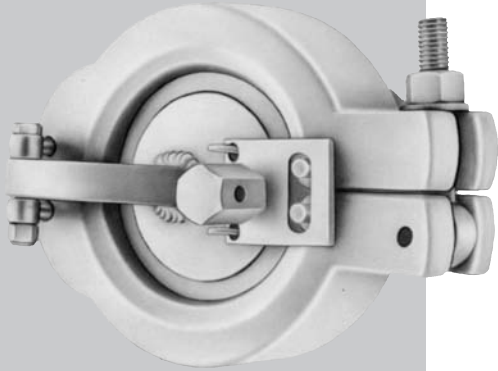

	Nominal Size	Over-all A	OD at Welding Bevel B	Back to Face Max. C	Hub Length D	Clear Hub Length E	Center to Head Stop F	Center to Free End G	Opening Clearance J	Yoke Clearance K	Center to Hinge L	Approx Weight Lbs
Class 150-S, 300S, 600S Single Bolt	2	4 7/8	2 3/8	2 3/4	3 1/8	1 9/16	2 5/8	3 5/8	4 1/16	6 1/8	2 1/4	10
	3	6 1/4	3 1/2	2 15/16	3 1/2	1 9/16	3 3/8	4 1/4	5 1/4	7 5/16	2 7/8	15
	4	7 3/8	4 1/2	3 1/8	4 1/4	2 7/16	4 13/16	5	6 9/16	8 5/16	3 11/16	25
	6	10	6 5/8	3 1/2	4 1/4	2 1/2	5 7/16	6 1/4	9	10 13/16	4 15/16	50
	8	11 15/16	8 5/8	4	4 1/4	2 1/16	6 3/8	7 3/8	10 3/4	13 11/16	5 3/4	70

All dimensions are in inches. When ordering, please specify type, nominal size, Bore, Material and service conditions. S-Bolt Closures are regularly furnished in carbon steel however, they are also available in other metals and alloys.

For small diameter piping

Because of space limitations, it usually is impractical and uneconomical to use double-bolt Hinged Closures for blanking off small openings in pipe lines and processing equipment. Tube Turns regularly furnishes single-bolt designs in sizes 2" through 8". The single-bolt adaptation provides significant advantages in many applications. There is only one bolt to operate, for example, and operating time is further reduced. And when speed of operation is a paramount requirement, the swing bolt design affords even greater savings of time and effort. Such standard features as tapered-surface sealing, hinged-head convenience and O-ring economy are retained in the single-bolt design.

Tube-Turns Single-Bolt Closures are offered in these designs:

Type	Nominal Sizes	ASME Pressure Rating
150-S	2" - 8"	150 lb (285 psi)
300-S	2" - 8"	300 lb (740 psi)
600-S	2" - 8"	600 lb (1480 psi)

Carbon steel is the standard material of construction for Tube Turns Single-Bolt Closures, but they also can be furnished in stainless steels and other materials depending upon customer requirements.

SINGLE BOLT CLOSURE PARTS

Class S/Swing Bolt Parts List			
1. Hub	6. Yoke (Upper)	10. Swing Bolt	15. Pressure Warning Device and Positioning Plate
2. Hub Hinge Lug	7. Yoke (Lower)	11. Swing Bolt Nut	16. Positioning Lugs
3. Head	8. Hinge Eye Bolt	12. Swing Bolt Pin	17. Washer
4. Hinge Arm	9. Cotter Pin (2" thru 6")	13. O-Ring	
5. Hinge Bolt	9A. Eye Bolt Nut (8")	14. Hinge Bolt Nut	

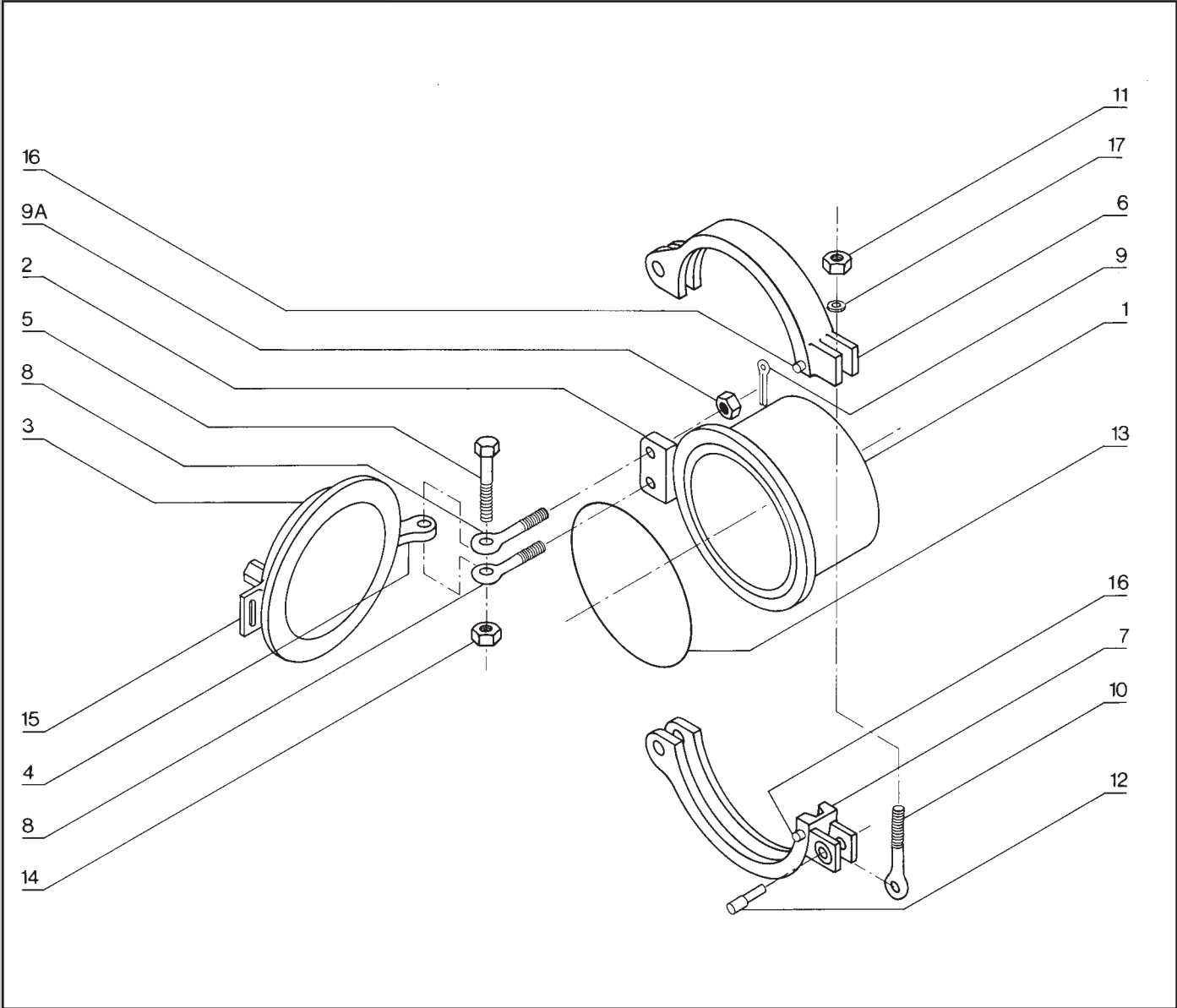

Spare Parts—It is suggested that the following spare parts be stocked for each closure:

Four O-Rings Part No. 13

When ordering spare parts, give amount, description, part number and size, pressure class and serial number of closure (located on front of yoke or ASME nameplate). Example: (1) O-ring - Part Number 13 - 8" CL600 - S/N 13845

PRESSURE WARNING DEVICE

Pressure Warning Device Parts List

- | | |
|----------------|----------------------|
| 1. Holding Nut | 5. Positioning Plate |
| 2. Gasket | 6. Hinge Pin |
| 3. Nipple | 7. Hinge |
| 4. Plate Stop | 8. Positioning Lugs |

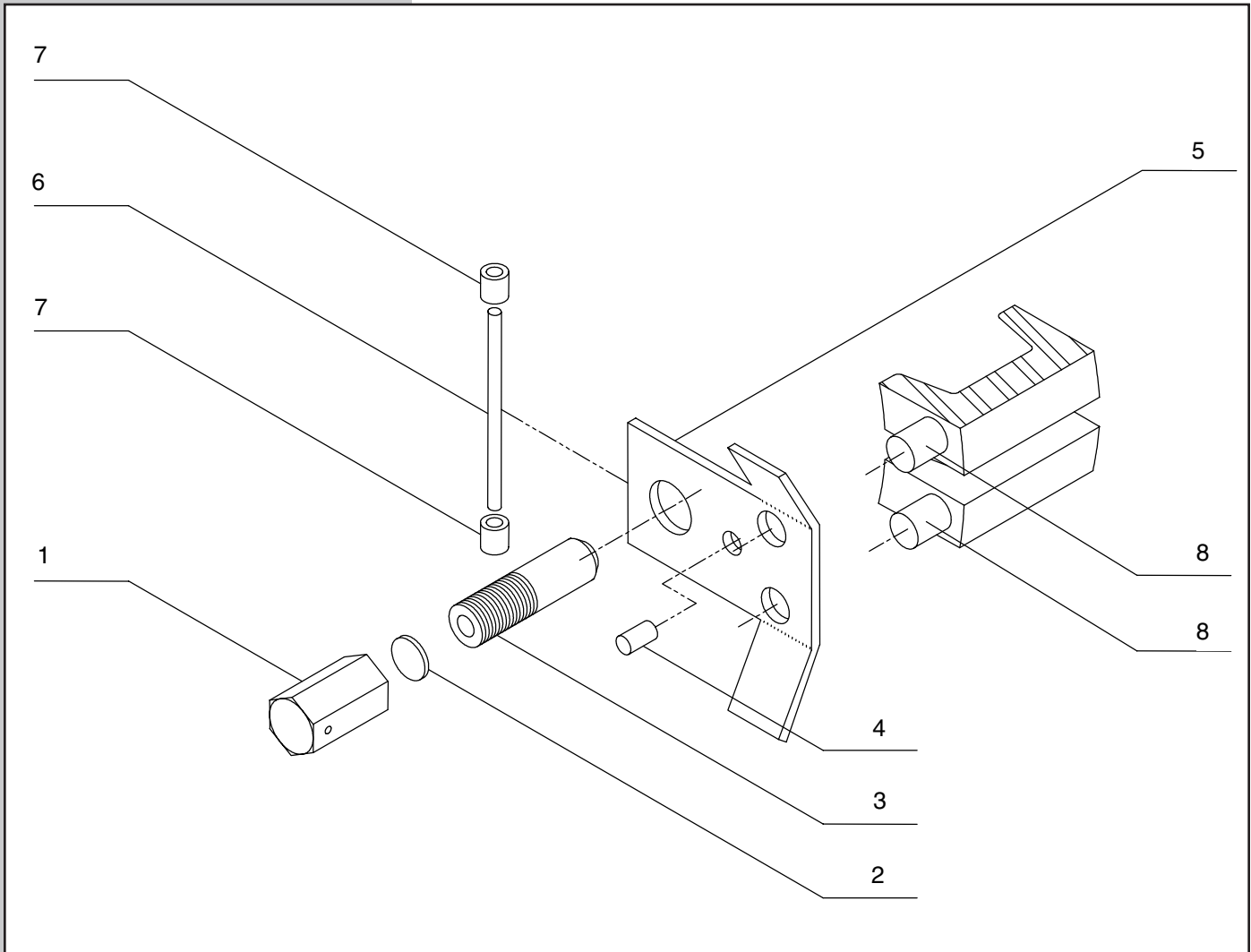



P.O. Box 32160
Louisville, KY 40232-2160

2612 Howard Street
Louisville, KY 40211

Phone: 502-774-6011
Fax: 502-774-6300

Website: www.sypris.com/TubeTurns

The information contained herein is based on data and information developed in the Laboratories of Sypris Technologies ("Seller"), but is presented without guarantee or warranty, and the seller disclaims any liability incurred from the use thereof. Nothing contained herein is to be construed as a recommendation for any use, including without limitation, any use in a commercial process not controlled by seller, nor for a use which is in violation of any existing patent, foreign or domestic or of applicable laws and regulations.